

DESCRIPTION

The MT7201C is a continuous mode inductive step-down converter, designed for driving single or multiple series connected LEDs efficiently from a voltage source higher than the LED voltage. The device operates from an input supply between 6V~40V and provides an externally adjustable output current of up to 1A.

The MT7201C includes the output switch and a high-side output current sensing circuit, which uses an external resistor to set the nominal average output current.

Output current can be adjusted below the set value, by applying an external control signal to the 'ADJ' pin.

The ADJ pin will accept either a DC voltage or a PWM waveform. Depending upon the control frequency, this will provide either a continuous or a gated output current. The PWM filter components are contained within the chip.

The PWM filter provides a soft-start feature by controlling the rise of input/output current. The soft-start time can be increased using an external capacitor from the ADJ pin to ground. Applying a voltage of 0.2V or lower to the ADJ pin turns the output off and switches the device into a low current standby state.

The device is assembled in a SOT89-5 pin package.

FEATURES

- Simple low parts count
- 1A output current
- Single pin on/off and brightness control using DC voltage or PWM
- Internal PWM filter
- Unique frequency Jitter technique to reduce EMI
- High efficiency (up to 97%)
- Wide input voltage range: 6V to 40V
- Output shutdown
- Up to 1MHz switching frequency
- Inherent open-circuit LED protection
- Typical 2% output current accuracy

APPLICATION CIRCUIT

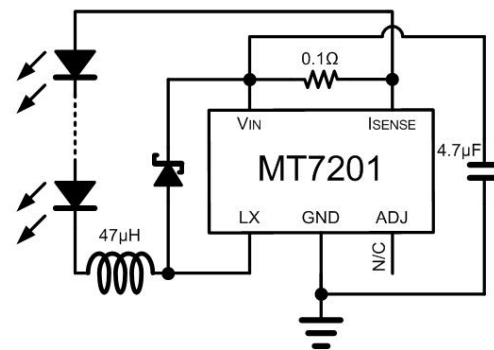

APPLICATION

- Low voltage halogen replacement LEDs
- Automotive lighting
- Low voltage industrial lighting
- LED back-up lighting
- Illuminated signs
- Stage lights