

規格承認書

PECIFICATION FOR APPROVAL

客戶
CUSTOMER : _____
項目
ITEM : 贴片式电磁无源蜂鸣器 (外部驱动)
型號
TYPE : GSC5025YA-12R4000
描述
DESCRIPTION : L5.2 x W5.2 x H2.0 MM 4000Hz 12 Ω ≥73DB 正发音 LCP 材质
客戶料號
CUSTOMER NO. : _____
規格書號
SPECIFICATION NO.: _____
版本
EDITION NO. : V1.1
日期
DATE : 2016-7-6

客戶承認

CUSTOMER CONFIRM AND SIGN

檢查 TESTED BY	審核 CHECKED BY	承認 APPROVED BY

東莞市贏海電子有限公司

DONGUAN INGHAI ELECTRONICS CO.,LTD

製作 ISSUED BY	審查 CHECKED BY	確認 APPROVED BY
周明	刘承成	

地址：廣東省東莞市長安鎮上沙第五工区新春科技园

電話 / TEL: 0769-83060958 傳真 / FAX: 0769-81608993

網址: [HTTP://WWW.INGHAI.COM](http://www.inghai.com)

A. SCOPE

This specification applies SMD piezoelectric buzzer, GSC5025YA-12R4000

B. SPECIFICATION

No.	Item	Unit	Specification	Condition
1	Oscillation Frequency	Hz	4000	Vo-p=1/2duty , square wave
2	Operating Voltage	Vo-p	2 ~ 4 Vo-p	
3	Rated Voltage	Vo-p	3.0 Vo-p	
4	Current Consumption	mA	Max.100mA	
5	Sound Pressure Level	dB	Min. 73dB	At Rated Voltage at 10cm
6	Coil Resistance	Ω	12 \pm 3	
7	Operating Temperature	$^{\circ}\text{C}$	-20 ~ +80	
8	Storage Temperature	$^{\circ}\text{C}$	-40 ~ +85	
9	Dimension	mm	5.2 x 5.2 x H2	See appearance drawing
10	Weight (MAX)	gram	0.5	
11	Environmental Protection Regulation		RoHS	

C. APPEARANCE DRAWING Tol : ± 0.3 Unit: mm

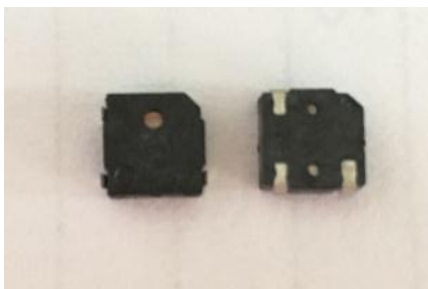

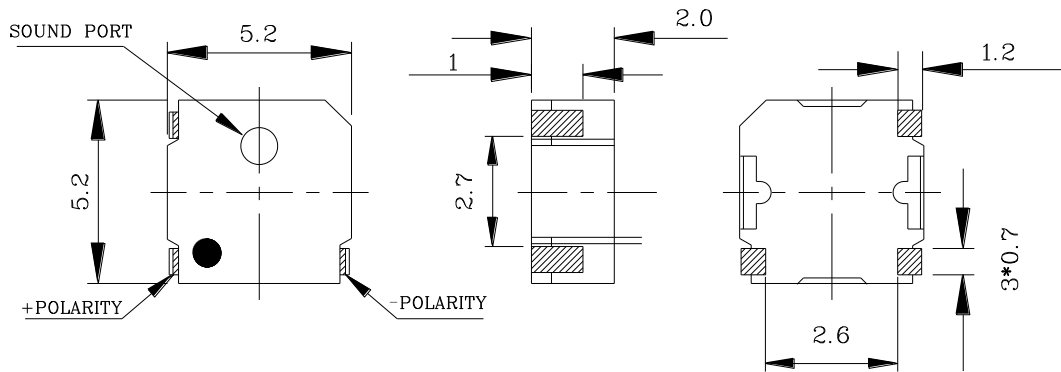

D: TEST METHOD:

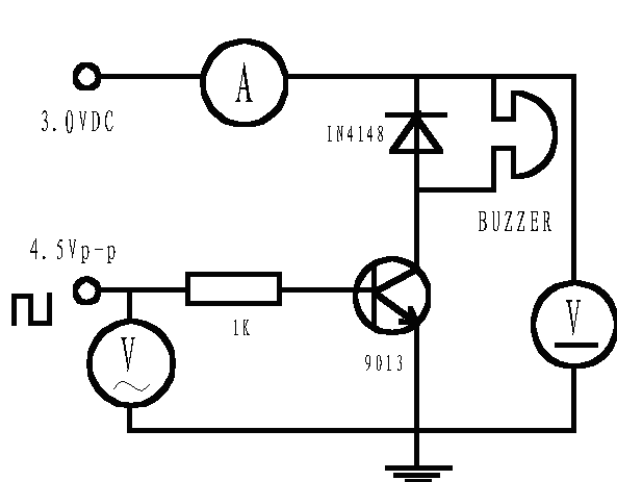

Test Circuit

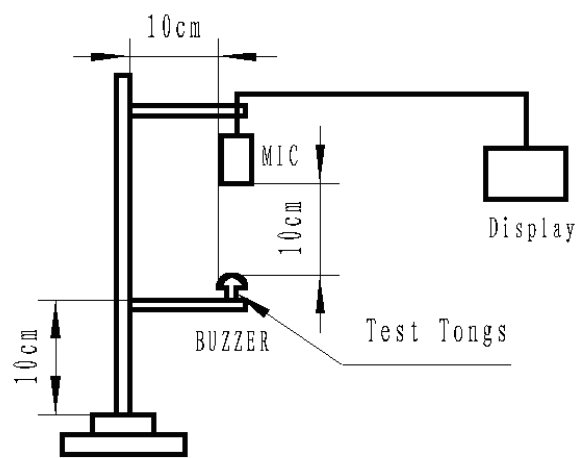

Test Equipis

E: FREQUENCY RESPONSE:

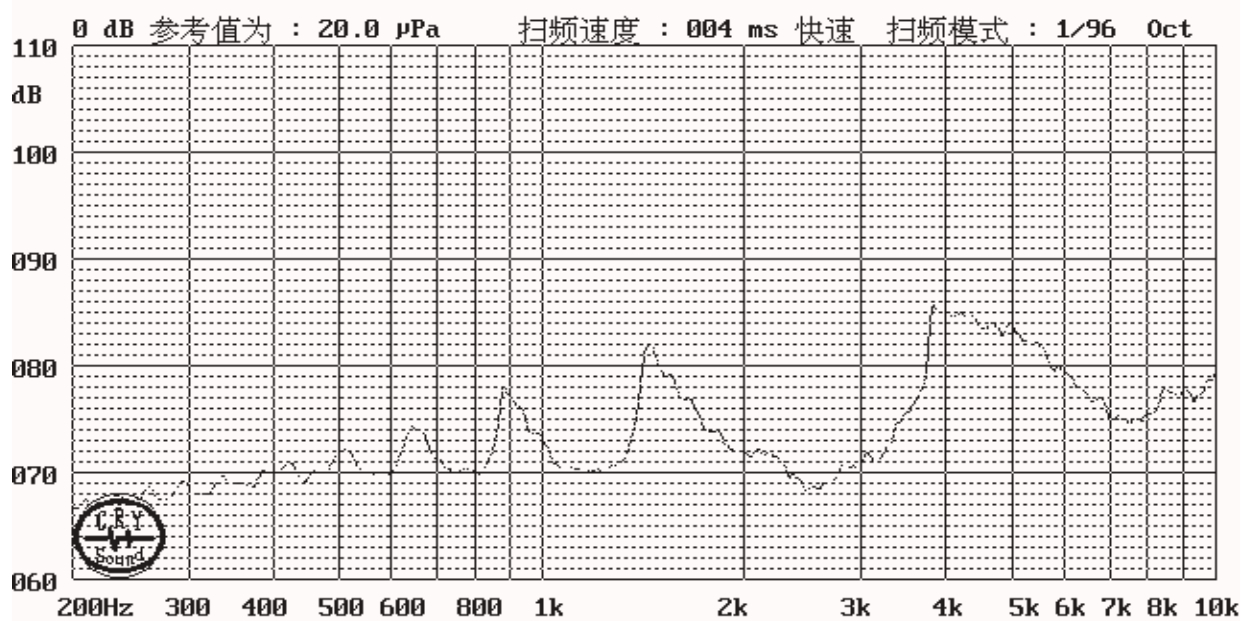

F. Soldering Condition

(1) Recommendable reflow soldering condition is as follows
(Reflow soldering is twice)

Note: It is requested that reflow soldering should be executed after heat of product goes down to normal.

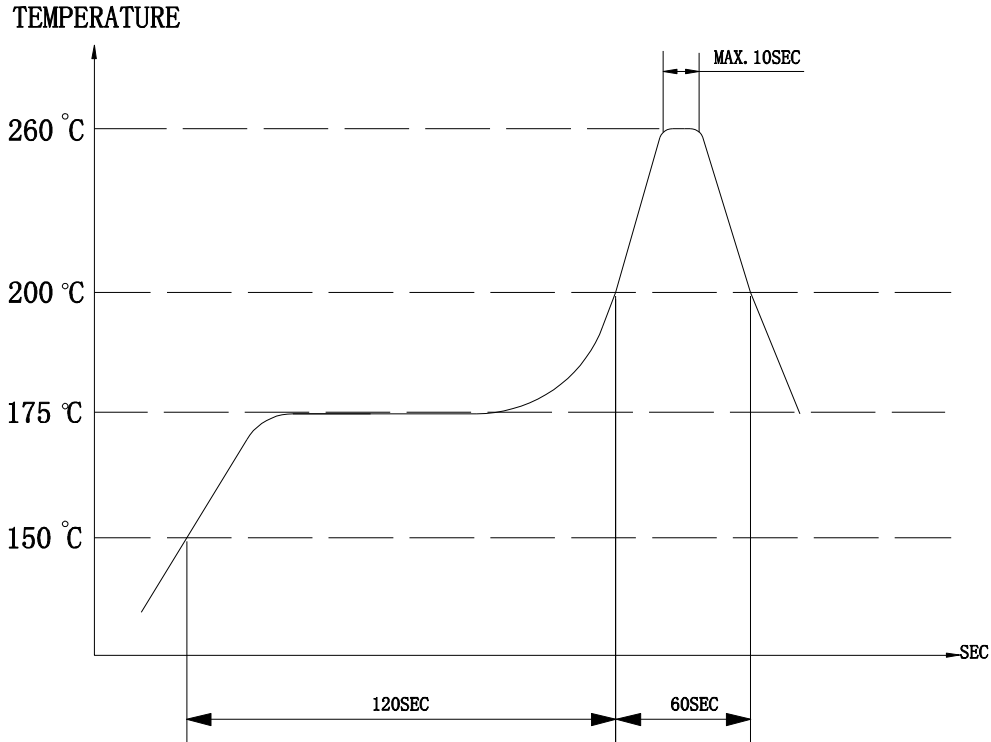

Heat resistant line
(Used when heat resistant reliability test is performed)

(2) Manual soldering
Manual soldering temperature 350 °C within 5 sec.

G: Reliability Test

After any following tests the part shall meet specifications without any degradation in appearance and performance except SPL. SPL shall not deviate more than -10 dB from the initial value

1. Ordinary Temperature Life Test

The part shall be subjected to 96 hours at $25 \pm 10^\circ\text{C}$. Input rated voltage Resonant frequency, 1/2 duty Square wave.

2. High Temperature Test

The part shall be capable of with standing a storage temperature of $+85^\circ\text{C}$ for 96 hours.

3. Low Temperature Test

The part shall be capable of with standing a storage temperature of -30°C for 96 hours.

4. Humidity Test

Temperature: $+40^\circ\text{C} \pm 3^\circ\text{C}$ Relative Humidity: 90%~95% Duration: 48 hours and expose to room temperature for 6 hours

5. Temperature Shock Test

Temperature: 70°C /1hour → 25°C /3hours → -30°C /1hour → 25°C /3hours (1cycle)
Total cycle: 10 cycles

6. Drop Test

Standard Packaging From 120mm(Drop on hard wood or board of 5cm thick, three sides, six plain.)

7. Vibration Test

Vibration: 1000cycles /min. Amplitude: 1.5mm, Duration: 1 hour in each 3 axes

Measuring condition

Part shall be measured under a condition (Temperature: $5 \sim 35^\circ\text{C}$, Humidity: 45%~85%R.H., Atmospheric pressure: 860 ~1060hPa) unless the standard condition (Temperature: $25 \pm 3^\circ\text{C}$, Humidity: $60 \pm 10\%$ R.H. Atmospheric pressure: 860 ~1060hPa) is regulated to measure.

Note:

As this product is not protected from foreign material entering, please make sure that any foreign materials (e.g. magnetic powder, washing solvent, flux, corrosive gas) do not enter this product in your production processes. The functional degradation (e.g. SPL down) may occur if foreign material enter it.

H:PACKING:

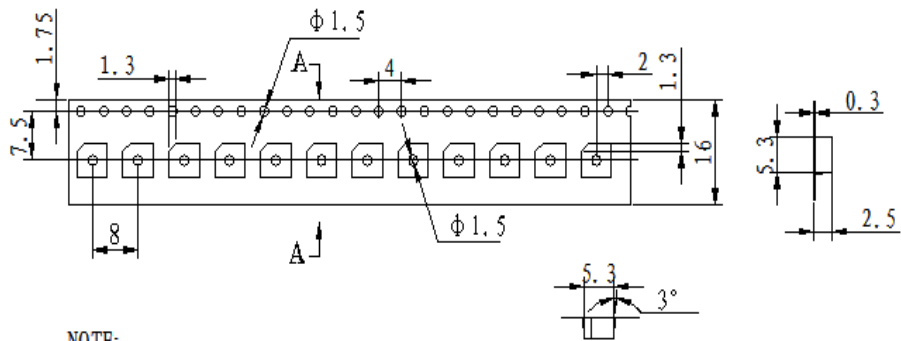

NOTE:

- 1.10 sprocket hole pitch cumulative tolerance ± 0.20 mm.
2. All dimensions meet EIA-481-D requirements.
3. Thickness: 0.3 ± 0.05 mm.
4. Component loaded per 13" reel: 2500pcs.

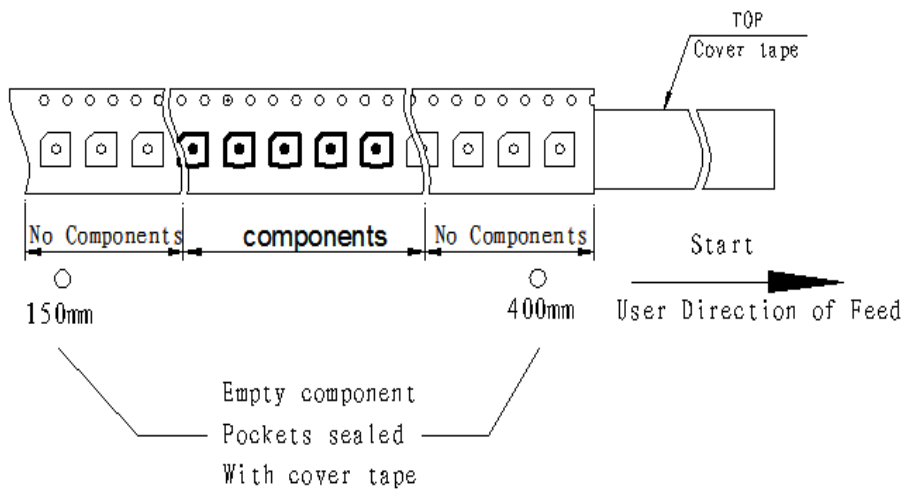
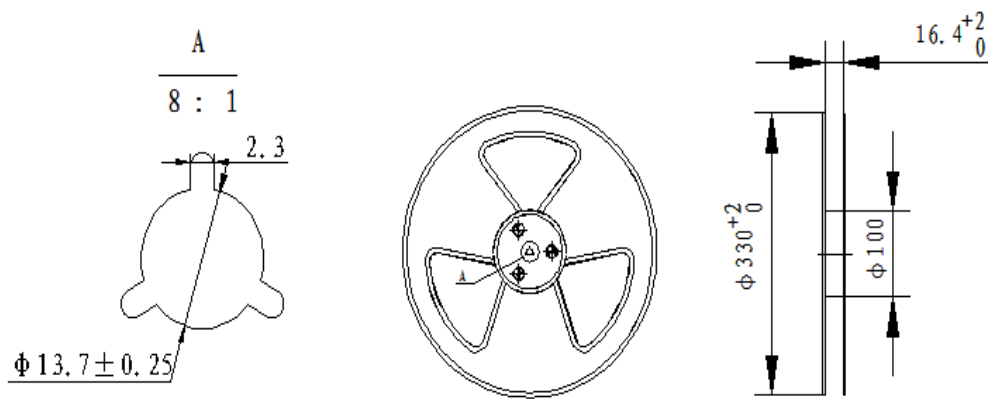

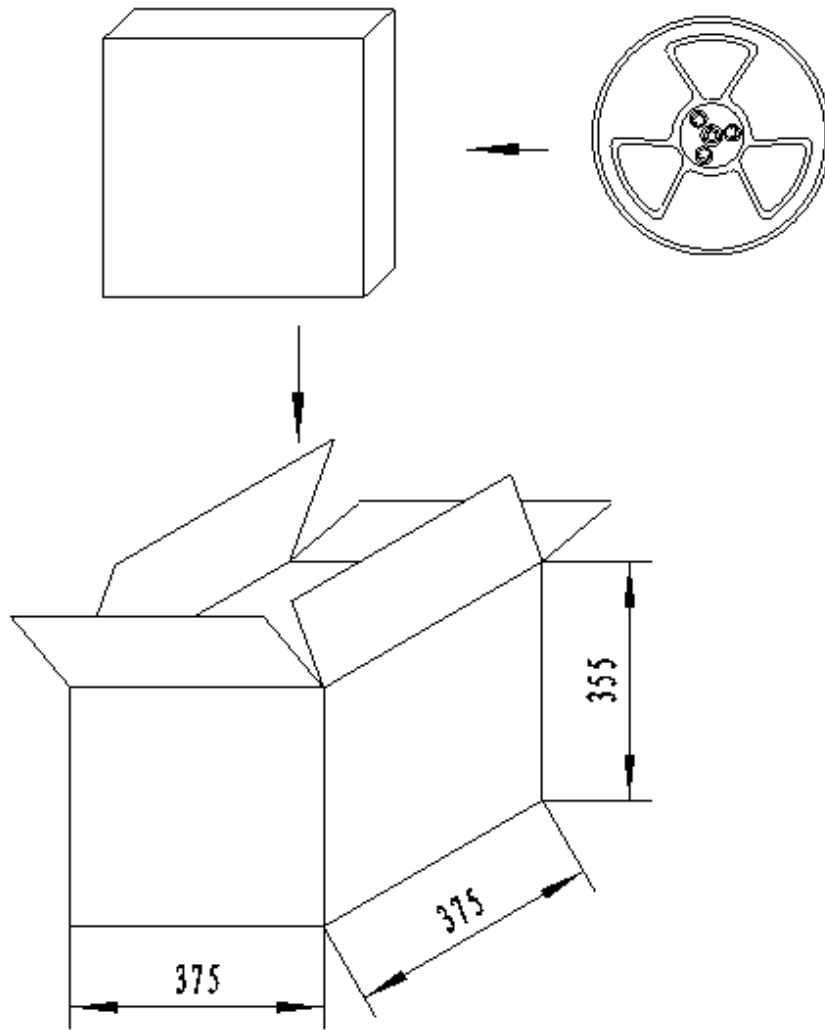

NOTES:

- 1.2500 PCS per box
2. 10 boxes / carton 25000 PCS
3. 4 boxes / carton 10000 PCS
- 4.产品保质期:真空包装保证 12 个月