



LTP02-245-13
THERMAL PRINTER MECHANISM
TECHNICAL REFERENCE

U00131701401

Seiko Instruments Inc.

LTP02-245-13 THERMAL PRINTER MECHANISM TECHNICAL REFERENCE

U00131701400 November 2013

U00131701401 July 2014

Copyright © 2013-2014 by Seiko Instruments Inc.
All rights reserved.

Seiko Instruments Inc. (hereinafter referred to as "SII") has prepared this manual for use by SII personnel, licensees, and customers. The information contained herein is the property of SII and shall not be reproduced in whole or in part without the prior written approval of SII.

SII reserves the right to make changes without notice to the specifications and materials contained herein and shall not be responsible for any damages (including consequential) caused by reliance on the materials presented, including but not limited to typographical, arithmetic, or listing errors.

SII ● is a trademark of Seiko Instruments Inc.

PREFACE

This technical reference (hereinafter referred to as "manual") describes the specifications and basic operating procedures for the LTP02-245-13 thermal printer mechanism (hereinafter referred to as "printer").

"CHAPTER 1 PRECAUTIONS" describes safety, design, and handling precautions. Read it thoroughly before designing so that you are able to use the product properly.

SII has not investigated the intellectual property rights of the sample circuits included in this manual. Fully investigate the intellectual property rights of these circuits before using.

In this manual, the description of negative logic has an additional "/" in the beginning of the terminal name. The input/output direction is described from the product side.

The printer complies with EU RoHS Directive (2011/65/EU)

The printer contains "Pb". The details are described below.

- Printer mechanism : a particular copper alloy parts, a particular free-cutting steel parts, a particular component in glass of the electronic parts

*Lead-containing items listed above are exempt from EU RoHS (2011/65/EU).

Identifying the parts of the printer as follows.

Printer mechanism

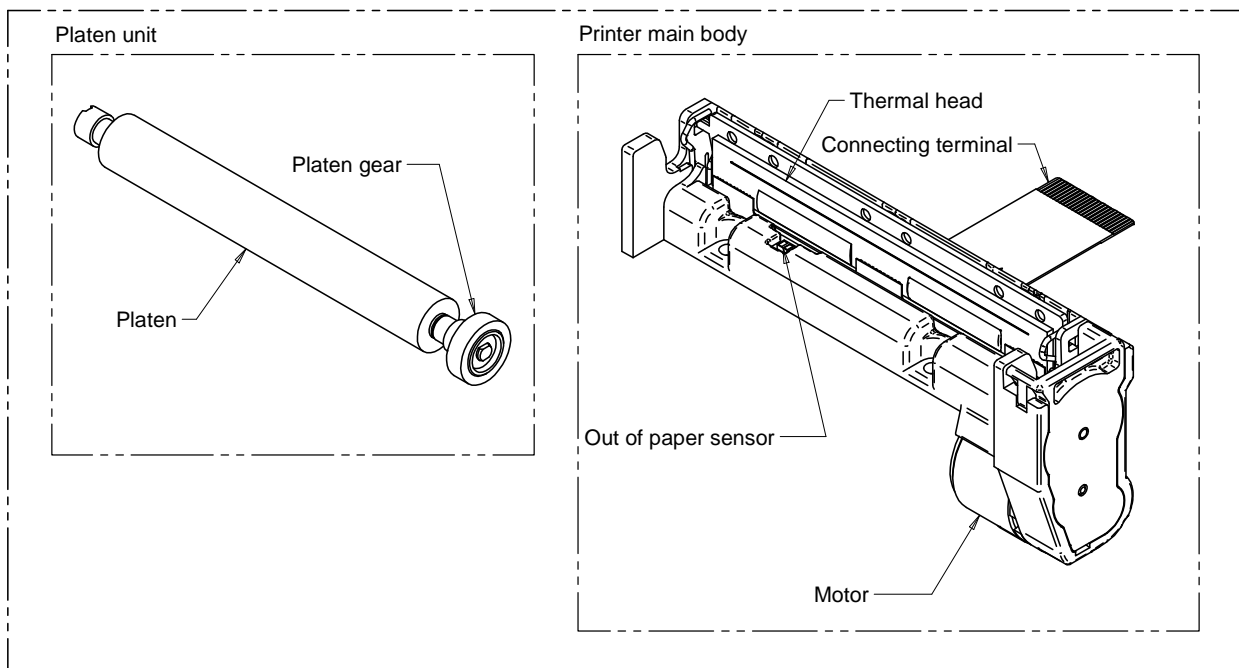

TABLE OF CONTENTS

CHAPTER1 PRECAUTIONS 1-1

1.1	SAFETY PRECAUTIONS.....	1-2
1.2	DESIGN AND HANDLING PRECAUTIONS	1-3
1.2.1	Design Precautions	1-3
1.2.2	Handling Precautions	1-5
1.2.3	Precautions on Discarding	1-6

CHAPTER2 FEATURES 2-1

CHAPTER3 SPECIFICATIONS 3-1

3.1	GENERAL SPECIFICATIONS	3-1
3.2	PRINT CONFIGURATION.....	3-3
3.3	STEP MOTOR	3-4
3.3.1	General Specifications	3-4
3.3.2	Sample Drive Circuit.....	3-5
3.3.3	Excitation Sequence.....	3-6
3.3.4	Motor Start/Stop Method	3-7
3.3.5	Motor Drive Method.....	3-8
3.3.6	Motor Drive Precautions.....	3-14
3.4	THERMAL HEAD	3-15
3.4.1	Structure of the Thermal Head.....	3-15
3.4.2	Print Position of the Data.....	3-16
3.4.3	Electrical Characteristics of Thermal Head.....	3-17
3.4.4	Timing Chart.....	3-18
3.4.5	Thermal Head Heat Element Resistance.....	3-18
3.4.6	Maximum Current Consumption	3-19
3.5	CONTROLLING THE ACTIVATION PULSE WIDTH FOR THERMAL HEAD....	3-20
3.5.1	Calculation of Activation Pulse Width.....	3-20
3.5.2	Calculation of Printing Energy	3-20
3.5.3	Adjustment of Thermal Head Resistance.....	3-21
3.5.4	Adjustment of Thermal Head Drive Voltage.....	3-21
3.5.5	Setting of Activation Pause Time	3-21
3.5.6	Adjustment by Thermal Head Activation Pulse Cycle.....	3-22
3.5.7	Calculation Sample for the Activation Pulse Width	3-23
3.5.8	Temperature Characteristics of Thermistor	3-24
3.5.9	Detecting Abnormal Temperature of the Thermal Head	3-26
3.6	OUT-OF-PAPER SENSOR	3-27
3.6.1	Precautions for the Out-of-Paper Sensor.....	3-27

CHAPTER4 CONNECTING TERMINALS 4-1

- 4.1 RECOMMENDED CONNECTOR FOR EXTERNAL CIRCUITS 4-1
- 4.2 CONNECTING TERMINALS..... 4-1

CHAPTER5 PRINT DRIVE METHOD 5-1

- 5.1 MOTOR AND THERMAL HEAD DRIVE METHOD 5-1
- 5.2 THERMAL HEAD DIVISION DRIVE METHOD..... 5-3
- 5.3 PRECAUTIONS FOR PRINT DRIVE 5-4

CHAPTER6 OUTER CASE DESIGN GUIDE 6-1

- 6.1 FIXING THE PRINTER MAIN BODY 6-1
 - 6.1.1 How to Mount the Printer Main Body 6-1
 - 6.1.2 Recommended Screws 6-2
 - 6.1.3 Precautions for Fixing the Printer Main Body..... 6-2
- 6.2 FIXING THE PLATEN UNIT 6-3
 - 6.2.1 Recommended Shape of the Platen Holder..... 6-3
 - 6.2.2 Dimensions for Positioning and Fixing the Platen Holder 6-4
 - 6.2.3 Precautions for Fixing the Platen Holder..... 6-5
- 6.3 CONNECT THE PRINTER TO FRAME GROUND (FG) 6-6
 - 6.3.1 How to Connect the Printer to Frame Ground (FG) 6-6
- 6.4 LAYOUT OF THE PRINTER MECHANISM AND THERMAL PAPER..... 6-7
- 6.5 WHERE TO MOUNT THE PAPER HOLDER 6-8
- 6.6 DESIGN PAPER EJECT 6-9
 - 6.6.1 Design the Shape of the Paper Eject 6-9
 - 6.6.2 Mount the Paper Cutter 6-10
- 6.7 PRECAUTIONS FOR DESIGNING THE OUTER CASE 6-11

CHAPTER7 EXTERNAL DIMENSIONS 7-1

CHAPTER8 HANDLING METHOD 8-1

- 8.1 PRECAUTIONS FOR INSTALLING/UNINSTALLING THE THERMAL PAPER... 8-1
- 8.2 PRECAUTIONS FOR CLEANING THE THERMAL HEAD..... 8-2

FIGURES

Figure 3-1	Print Dot Pitch	3-3
Figure 3-2	Print Area	3-3
Figure 3-3	Sample Drive Circuit	3-5
Figure 3-4	Input Voltage Waveforms for the Sample Drive Circuit	3-6
Figure 3-5	Motor Start/Stop Timing Chart	3-7
Figure 3-6	Thermal Head Block Diagram	3-15
Figure 3-7	Transfer Data and Print Position	3-16
Figure 3-8	Thermal Head Drive Timing Chart	3-18
Figure 3-9	the Time Between the Beginning of the Last Thermal Head Activation and the Beginning of Present Thermal Head Activation (W')	3-22
Figure 3-10	Temperature Characteristics of the Thermistor	3-24
Figure 3-11	Sample External Circuit of the Out-of-paper Sensor	3-27
Figure 4-1	Connecting Terminals	4-1
Figure 5-1	Divided Print Timing Chart Sample	5-1
Figure 6-1	Dimensions for Positioning and Fixing the Printer Main Body	6-1
Figure 6-2	Dimensions for Positioning and Fixing the Platen Unit	6-3
Figure 6-3	Dimensions for Positioning and Fixing the Platen Holder	6-4
Figure 6-4	Frame Ground (FG) Connecting Area	6-6
Figure 6-5	Recommended Layout between the Printer and the Paper	6-7
Figure 6-6	Recommended Paper Holder Dimensions	6-8
Figure 6-7	Paper Path	6-9
Figure 6-8	Blade Edge	6-10
Figure 7-1	External Dimensions of the Platen Unit	7-1
Figure 7-2	External Dimensions of the Printer Mechanism	7-2
Figure 8-1	Cleaning Position of the Thermal Head	8-2

TABLES

Table 3-1	General Specifications	3-1
Table 3-2	General Specifications of the Step Motor	3-4
Table 3-3	Excitation Sequence	3-6
Table 3-4	Maximum Motor Drive Pulse Rate	3-8
Table 3-5	Acceleration Steps	3-10
Table 3-6	Maximum Continuous Drive Time and Drive Ratio.....	3-11
Table 3-7	Drive Time and Paper Length at Temperature Rise 50°C.....	3-12
Table 3-8	Drive Time and Paper Length at Temperature Rise 75°C.....	3-13
Table 3-9	DST and Heating Elements.....	3-15
Table 3-10	Electrical Characteristics of Thermal Head.....	3-17
Table 3-11	Thermal Head Heat Element Resistance.....	3-18
Table 3-12	Standard Printing Energy and Temperature Coefficient.....	3-20
Table 3-13	Activation Pulse Width	3-23
Table 3-14	Temperature Characteristics of the Thermistor	3-25
Table 3-15	Out-of-paper Sensor	3-27
Table 4-1	Recommended Connectors	4-1
Table 4-2	Terminal Assignments of the Connecting Terminal	4-2

CHAPTER 1

PRECAUTIONS

Read through this manual to design a product and to operate the printer properly. Pay special attention to the precautions noted in each section for details. Information contained in this manual is subject to change without notice.

For the latest information, contact our sales representative.

Sufficient evaluation and confirmation should be performed with the designed outer case mounted, to ensure proper use of the printer.

SII shall not be liable for any and all claims, actions, lawsuits, demands, costs, liabilities, losses, damages and/or expenses that are caused by improper handling of the printer, any use not contained in this manual or that result from the outer case, unless such damages and/or loss originate from the printer itself.

SII makes no warrant that your products into which built the sample circuits included in this manual can work properly and safe. You shall evaluate and confirm sufficiently that such products can work properly and safe, and shall be liable for any and all claims, actions, lawsuits, demands, costs, liabilities, losses, damages and/or expenses arising out of or in relating to such products.

SII has not investigated the intellectual property rights of the sample circuits included in this manual. Fully investigate the intellectual property rights of these circuits before using.

The printer is designed and manufactured to be mounted onto general electronic equipment. If high reliability is required of the printer in respect to hazardous influences on the body or life and loss to property, redundant design of the entire system should be carried out and verify the performance with your actual device before commercialization. And our sales representative should be informed as such in advance.

Follow the precautions listed below when designing a product using the printer. Include any necessary precautions into your operation manual to ensure safe operation of your product by users.

1.1 SAFETY PRECAUTIONS

Follow the precautions listed below when designing your product for using safely. Include any necessary precautions into your operation manual and attach warning labels to your products to ensure safe operation.

- **Precautions to prevent the thermal head from overheating**

When the thermal head heat elements are continuously activated by a CPU or other malfunction, the thermal head may overheat and may cause smoke and fire. Follow the method described in "3.5.9 Detecting Abnormal Temperature of the Thermal Head" to monitor the temperature of the thermal head to prevent overheating. Turn the printer off immediately if any abnormal conditions occur.

- **Precautions for rising temperatures of the thermal head**

Temperature of the thermal head and its peripherals rises very high during and immediately after printing. Be sure to design the outer case to prevent users from burn injuries by touching them. Place warning labels to warn users to ensure safe operation. As for thermal head cleaning, warn users to allow the thermal head to cool before cleaning. In order to allow cooling, secure clearance between the thermal head and the outer case when designing the outer case.

- **Precautions for rising temperatures of the motor**

Temperature of the motor and its peripherals rises very high during and immediately after printing. Be sure to design the outer case to prevent users from burn injuries by touching them. Place warning labels to warn users to ensure safe operation. In order to allow cooling, secure clearance between the motor and the outer case when designing the outer case.

- **Precautions for sharp edges of the printer**

The printer may have some sharp edges and cutting surfaces of the metal parts. Be sure to design the outer case to prevent users from injuring himself/herself by touching the sharp edges and place warning labels to warn users to ensure safe operation.

- **Precautions for motor drive**

The hair may get caught in the exposed platen and the gears. Control the motor not to drive when the outer case and the platen unit is in open state. Also, make sure to design the outer case so as not to touch the platen and the gears and also prevent any objects from getting caught. Place warning labels to warn users to ensure safe operation.

1.2 DESIGN AND HANDLING PRECAUTIONS

To maintain the primary performance of the printer and to prevent future problems from occurring, follow the precautions below.

1.2.1 Design Precautions

- Apply power in the following manner:
At power on : (1) Vdd → (2) Vp
At shut down : (1) Vp → (2) Vdd
- A surge voltage between Vp and GND should not exceed 10V.
- For noise countermeasure, connect a 0.1 μ F capacitor between Vdd and GND pins near the connector.
- Make the wire resistance between the power supply (Vp and GND) and the printer (connecting terminals) as small as possible (below 50m Ω). Keep distance from signal lines to reduce electrical interference.
- The sensor may generate instantaneous abnormal signal. Design the firmware in order to prevent malfunction due to the abnormal signal.
- Keep the Vp power off during not printing in order to prevent the thermal head from electrolytic corrosion. In addition, design the product so that the Signal Ground (GND) of the thermal head and the Frame Ground (FG) of the printer become the same electric potential.
- Use C-MOS IC chips for CLK, /LAT, DI and DST signals of the thermal head.
- When turning the power on or off, or during not printing, always disable the DST.
- To prevent the thermal head from being damaged by static electricity:
 - (1) Connect the printer Frame Ground (FG) connecting area to the Frame Ground (FG) of the outer case. See "CHAPTER 6 OUTER CASE DESIGN GUIDE" for details.
 - (2) Connect the Signal Ground (GND) to the Frame Ground (FG) through approximately 1 M Ω resistance.
- Always detect the outputs of the platen position sensor and out-of-paper sensor. Never activate the thermal head when there is no thermal paper. Incorrect activation of the thermal head may reduce the life of the thermal head and the platen and may damage them.
- A pause time between thermal head activations of the same heat element shall be secured more than 0.5ms. Pay attention to when using one division printing or when a thermal head activation time becomes longer. If activating for a long time without the pause time, the thermal head may become damaged.
- If too much energy is applied to the thermal head, it may overheat and become damaged. Always use the printer with the specified amount of energy shown in "3.5 CONTROLLING THE ACTIVATION PULSE WIDTH FOR THERMAL HEAD".
- Operation sound and vibration during printing vary depending on the motor pulse rate. Verify the performance with your actual device.
- Paper feed force can be decreased depending on the motor pulse rate. Verify the performance with your actual device.
- Do not perform continuous printing to prevent the motor from overheating. Refer to "3.3.5 Motor Drive Method" to set a pause time.
- Paper feeding may be confused with several dot lines when printing is started from waiting status. When printing and paper feeding are interrupted and then started printing, as this may cause the paper feeding be confused. When printing bit images and so on, always feed the thermal paper for more than 48 steps at start up and do not interrupt printing.

- To prevent degradation in the print quality due to the backlash of the paper drive system, feed the thermal paper for 48 steps or more at the initialization, at a time after setting/releasing the platen unit, a time after feeding the thermal paper backward and a time after cutting with a paper cutter.
- Surface of the thermal paper may get scratched by backward feed. The backward feed may cause paper skew and jams depending on the paper roll layout and designing of the paper holder. Be sure to confirm performance with your product before using the backward feed.
- If printing at a high print ratio for longer length, non-printing area may be colored due to an accumulation of heat. Verify the performance with your actual device.
- Do not print without the thermal paper. It may cause damage the platen and the thermal head.
- It is recommended that the platen holder is guided by part of the outer case, when the platen unit is set into the printer main body. If you set the mounting part of the printer and rotation center part of the platen holder to the same base, accuracy for setting or releasing the platen unit will improve.
- Design the outer case that holds the platen holder so that the center of the platen unit of the printer mechanism is pushed. When the edge of the platen unit is pushed, a one-sided lock phenomenon happens, and print defect and/or a paper jam may occur. It is helpful to indicate which location has to be pushed by showing a symbol on the outer case. Verify the performance with your actual device.
- If the printer main body and the platen unit are not placed in proper position, the print defect and the paper jam may occur. Therefore, pay special attention to it when designing the outer case. For the position relation between the printer main body and the platen unit, see "CHAPTER 6 OUTER CASE DESIGN GUIDE".
- Design the platen holder and the outer case strong enough to keep the allowable dimensions because stress is applied to them when setting and releasing the platen unit. The rotation center for the rotation system of the platen holder should be designed to fit the rotational shaft into the shaft hole so that the platen unit should be stable when it is in the close state.
- Design the thermal paper supply system in accordance with "CHAPTER 6 OUTER CASE DESIGN GUIDE". When the thermal paper supply position is improper, print difficulty or paper detection difficulty will be caused and the surface of thermal paper may get scratched. Verify the performance with your actual device.
- Do not use labeling paper, 2-ply thermal paper, and thermal paper with thickness of 75 μ m or thicker.
- Design the product so that a tension force is not applied to the FPC. The FPC could be moved by setting/releasing the platen unit, so design the product so that the FPC has enough play after connected it. The tension force may cause some print problems and may damage the FPC.
- Metal parts may become discolored and rusted due to the operational environment. Consider these factors regarding appearance.
- Do not apply external force continuously toward the direction the platen unit is released. Otherwise, it may cause slipping gears, negative influence on printing quality, and printing troubles during operation.

1.2.2 Handling Precautions

Incorrect handling may reduce the efficiency of the printer and cause damage. Handle the printer with the following precautions.

Also, include any necessary precautions so that users handle the printer with care.

- Using anything other than the specified thermal paper does not guarantee print quality and life of the thermal head.
The followings are examples of trouble:
 - (1) Poor printing quality due to low thermal sensitivity
 - (2) Abrasion of the thermal head due to paper surface roughness
 - (3) Printing stuck and unusual noise due to sticking the thermal layer of the thermal paper to the thermal head
 - (4) Printing fade due to low preservability of the thermal paper
 - (5) Electrolytic corrosion of the thermal head due to inferior paper
- After the printer has been left not in use for long period of time, the platen could be deformed and resulted in print quality deteriorated. In this case, feed thermal paper for a while to recover deformation of the platen. If the thermal head is remained in contact with the platen without thermal paper for a long time, the platen and the thermal head may be stuck together and cause paper feed difficulty. If facing this problem, release the platen unit, and set it back again before starting printing.
- Never loosen the screws that fasten respective parts of the printer. Loosened screws may reduce the efficiency of the performance of the printer mechanism.
- Do not release the platen unit during printing; otherwise this may reduce the efficiency of the printer and may cause damage.
- Do not apply stress to the platen unit during printing. The print defect may occur.
- When setting the platen unit, the reduction gear may interfere with the platen gear and may cause the platen unit to not be set. In such a case, release the platen unit and set it again.
- Never pull out the thermal paper while the platen unit is set. The printer mechanism may become damaged.
- When handling the printer, make sure to use antistatic clothing and to ground yourself to prevent the thermal head from damaged by static electricity. Especially take care of the thermal head heat element and the connecting terminal.
- Do not hit or scratch the surface of the thermal head with any sharp or hard object. This could damage the thermal head.
- When printing at a high print ratio in a low temperature or high humidity environment, the vapor from the thermal paper during printing may cause condensation to form on the printer and soil the thermal paper itself. Prevent the thermal head from a drop of water. It may cause electrolytic corrosion of the thermal head. If condensed, do not activate electricity until dried.
- Connect or disconnect the connecting terminal after turn off the power.
- Do not apply stress to the FPC while connecting and disconnecting them. Otherwise the FPC may become damaged.
- Warn users not to pull the thermal paper and not to change the paper eject angle during printing. Otherwise, the print defect or the paper jam may occur.
- In order to prevent the thermal head from damage and to avoid the print defect, warn users not to touch the thermal head and the sensor directly when handling the printer like replacing thermal paper.
- Do not use the paper roll with glued end or folded end. In case of using such paper roll, replace to a new one before the end of the paper roll is shown up.

- The printer is not waterproof and drip proof. Prevent contact with water and do not operate with wet hands as it may damage the printer or may cause a short circuit or fire.
- The printer is not dust proof. Never use the printer in a dusty place, as it may damage the thermal head and paper drive system.
- Do not use the printer in corrosive gas and siloxane atmosphere as it may cause the contact failure.

1.2.3 Precautions on Discarding

When discarding used printers, discard them according to the disposal regulations and rules of each respective district.

CHAPTER 2

FEATURES

The printer is a compact printer that adopts a thermal line dot printing method. It can be used with measuring instruments and analyzer, a POS, a communication terminal device, or a data terminal device.

The printer has the following features:

- **High resolution printing**
A high-density print head of 8 dots/mm produces clear and precise printing.
- **Compact**
Dimensions : W67.3mm × D18.1mm × H30.0mm
Mass : approx. 28 g
- **High print speed***
Maximum 100mm/s print is available.
- **Easy operation**
Platen unit open mechanism provides easy paper installation.
- **Maintenance Free**
No cleaning and no maintenance required.
- **Low noise**
Thermal printing technology realizes low-noise print.

* Print speed differs depending on working conditions.

CHAPTER 3 SPECIFICATIONS

3.1 GENERAL SPECIFICATIONS

Table 3-1 lists the general specifications of the printer.

Table 3-1 General Specifications

(1/2)

Items	Specifications
Printing method	Thermal line dot printing method
Total dots per line	384 dots
Printable dots per line	384 dots
Simultaneously activated dots	45 dots
Resolution	W 8 dots/mm × H 16 dots/mm ^{*1}
Paper feed pitch	0.03125 mm
Maximum print speed	100 mm/s ^{*2}
Print width	48 mm
Paper width	58 ⁰ ₋₁ mm
Thermal head temperature detection	Thermistor
Platen position detection	None
Out-of-paper detection	Reflection type photo interrupter
Operating voltage range	
Vp line	5.5 V to 9.5 V
Vdd line	3.0 V to 3.6 V
Current consumption	
Vp line Thermal head drive	2.64 A max. (at 9.5 V) ^{*3}
Motor drive	0.60 A max.
Vdd line Thermal head logic	0.10 A max.

Items		Specifications										
Operating temperature range		-10°C to 50°C (Non condensing)										
Operating humidity range												
Storage temperature range		-20°C to 60°C (Non condensing)										
Life span (at 25°C and rated energy)	Activation pulse resistance	100 million pulses or more ^{*4}										
	Abrasion resistance	50 km or more ^{*5}										
Paper feed force		0.49 N (50 gf) or more										
Paper hold force		0.78 N (80 gf) or more										
Dimensions (excluding convex part)		W 67.3 mm × D 18.1 mm × H 30.0 mm										
Mass		Approx. 28g										
Specified thermal paper		<table border="0"> <tr> <td>Nippon Paper</td> <td>TF50KS-E2D</td> </tr> <tr> <td>Jujo Thermal</td> <td>AF50KS-E</td> </tr> <tr> <td></td> <td>AP45KS-NP</td> </tr> <tr> <td>Mitsubishi Hi-Tech Paper</td> <td>F5041</td> </tr> <tr> <td>Papierfabrik August Koehler AG</td> <td>KT55F20</td> </tr> </table>	Nippon Paper	TF50KS-E2D	Jujo Thermal	AF50KS-E		AP45KS-NP	Mitsubishi Hi-Tech Paper	F5041	Papierfabrik August Koehler AG	KT55F20
Nippon Paper	TF50KS-E2D											
Jujo Thermal	AF50KS-E											
	AP45KS-NP											
Mitsubishi Hi-Tech Paper	F5041											
Papierfabrik August Koehler AG	KT55F20											

*1 : See "CHAPTER 5 PRINT DRIVE METHOD" for printing drive method.

*2 : Print speed changes according to the processing speed of the controller and print pulse width.

*3 : The value when the number of simultaneously activated dots is 45 dots.

*4 : Excluded when the same dots are printed continuously.

*5 : Excluding damage caused by dust and foreign materials.

3.2 PRINT CONFIGURATION

Figure 3-1 shows print dot pitch. Figure 3-2 shows print area.

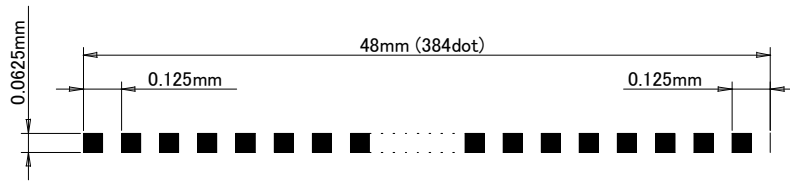

Figure 3-1 Print Dot Pitch

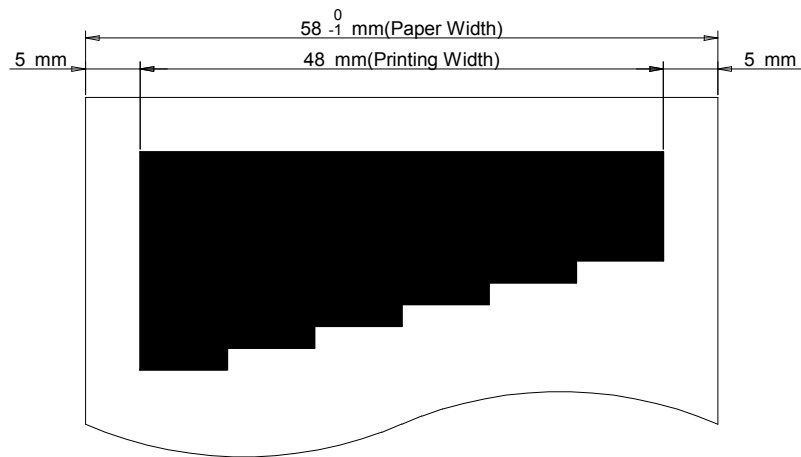

Figure 3-2 Print Area

3.3 STEP MOTOR

3.3.1 General Specifications

Table 3-2 shows general specifications of the step motor.

Table 3-2 General Specifications of the Step Motor

Item	Specifications
Type	PM type step motor
Drive method	Bipolar chopper drive
Excitation	1-2 phase
Winding resistance per phase	8.3 Ω /phase \pm 10%
Motor drive voltage	V _p : 5.5 V to 9.5 V
Motor controlled current	300 mA/phase
Drive pulse rate	3200 pps max.

3.3.2 Sample Drive Circuit

Figure 3-3 shows a sample drive circuit.

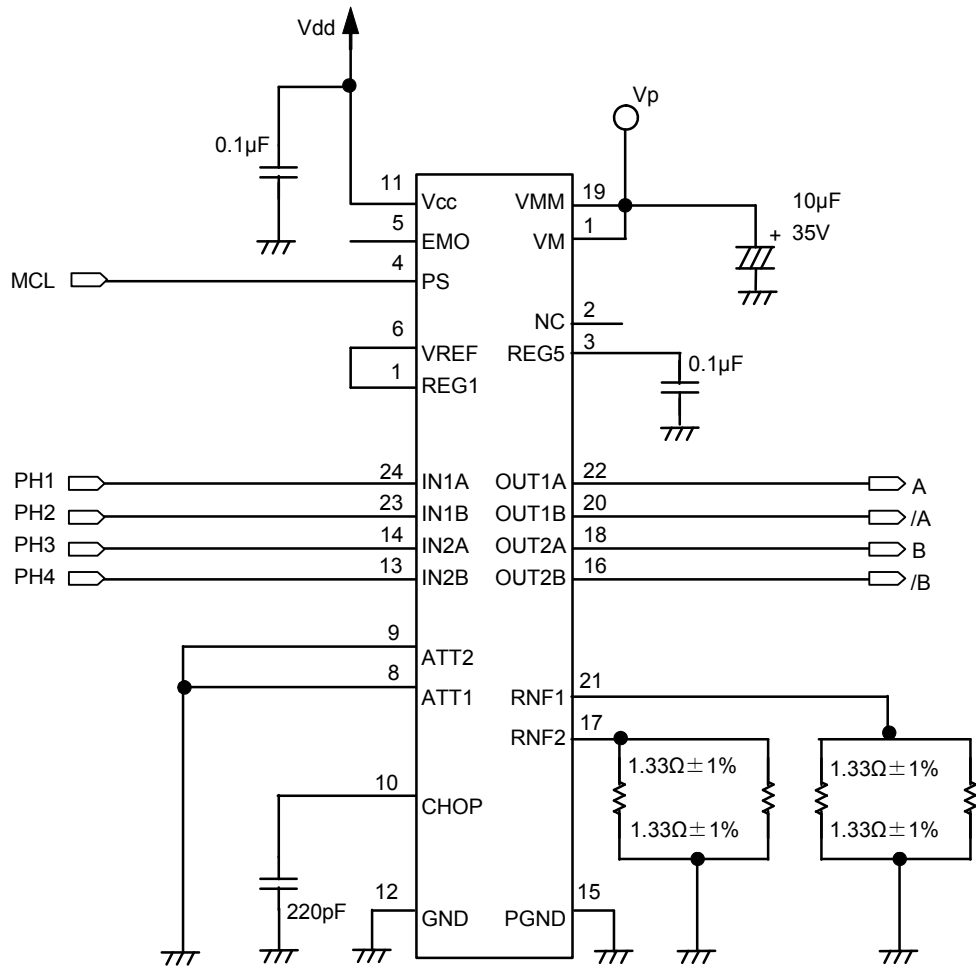

*: Recommended motor driver : LV8711T (SANYO)

Figure 3-3 Sample Drive Circuit

3.3.3 Excitation Sequence

Drive the motor with 1-2 phase excitation. One step of the motor drive signal feeds the paper 0.03125 mm. One dot line is consisted of 4 steps. When the voltage signal shown in Figure 3-4 is input to the motor drive circuit shown in Figure 3-3, the printer feeds the paper in the normal direction when the motor is excited in order of step 1, step 2, step 3, step 4, step 5, step 6, step7, step 8, step 1, step 2, , as shown in Table 3-3.

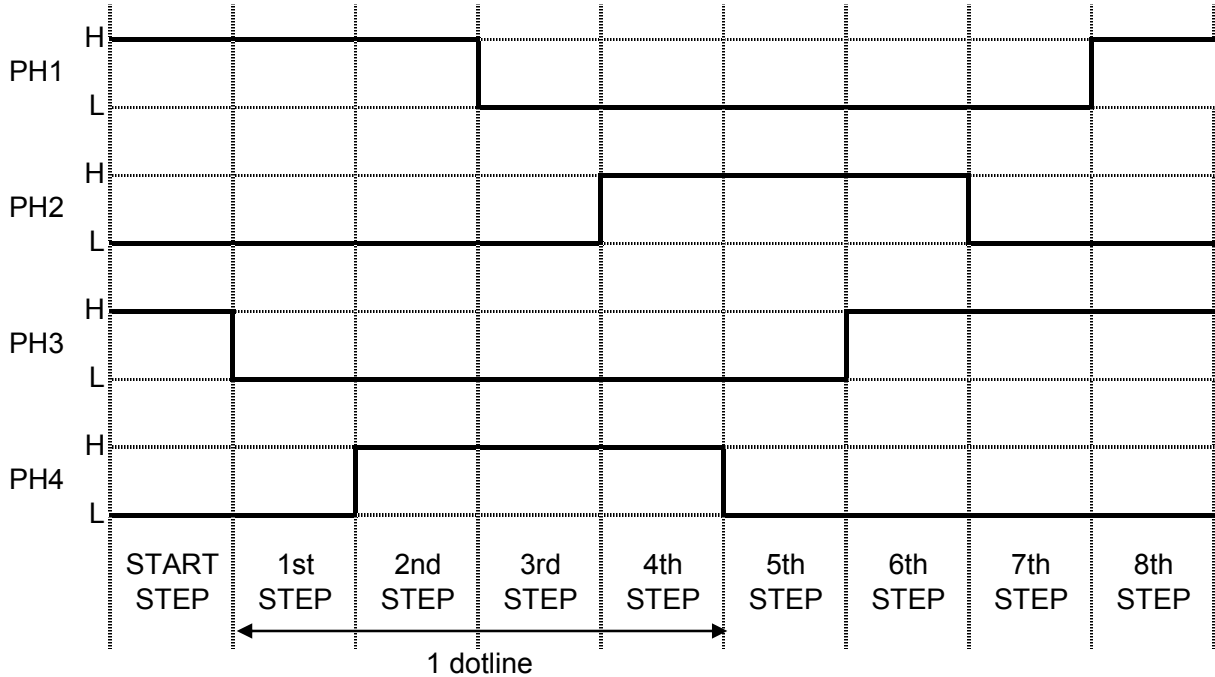

*1: Set MCL to "High" while the motor is driven.

Figure 3-4 Input Voltage Waveforms for the Sample Drive Circuit

Table 3-3 Excitation Sequence

	Input Signal				Output Signal			
	PH1	PH2	PH3	PH4	A	/A	B	/B
Step1	H	L	L	L	H	L	OFF	OFF
Step2	H	L	L	H	H	L	L	H
Step3	L	L	L	H	OFF	OFF	L	H
Step4	L	H	L	H	L	H	L	H
Step5	L	H	L	L	L	H	OFF	OFF
Step6	L	H	H	L	L	H	H	L
Step7	L	L	H	L	OFF	OFF	H	L
Step8	H	L	H	L	H	L	H	L

3.3.4 Motor Start/Stop Method

Refer to the timing chart in Figure 3-5 when designing the control circuit or software for starting and stopping the motor. Also note the following precautions:

(1) Start step

To start the motor from the pause (no excitation) state, shift the motor to the sequence of print step after exciting the same phase as that of the stop step for the first acceleration step time of the acceleration step.

To restart the motor from the stop step, immediately shift the motor to the sequence of print step.

(2) Stop step

To stop the motor, excite the same phase as the last one in the printing step for 65ms.

(3) Pause state

In the pause state, do not excite the motor to prevent to the motor from overheating. Even when the motor is not excited, holding torque of the motor prevents the thermal paper from moving.

Input signals for a sample drive circuit are shown in Figure 3-5.

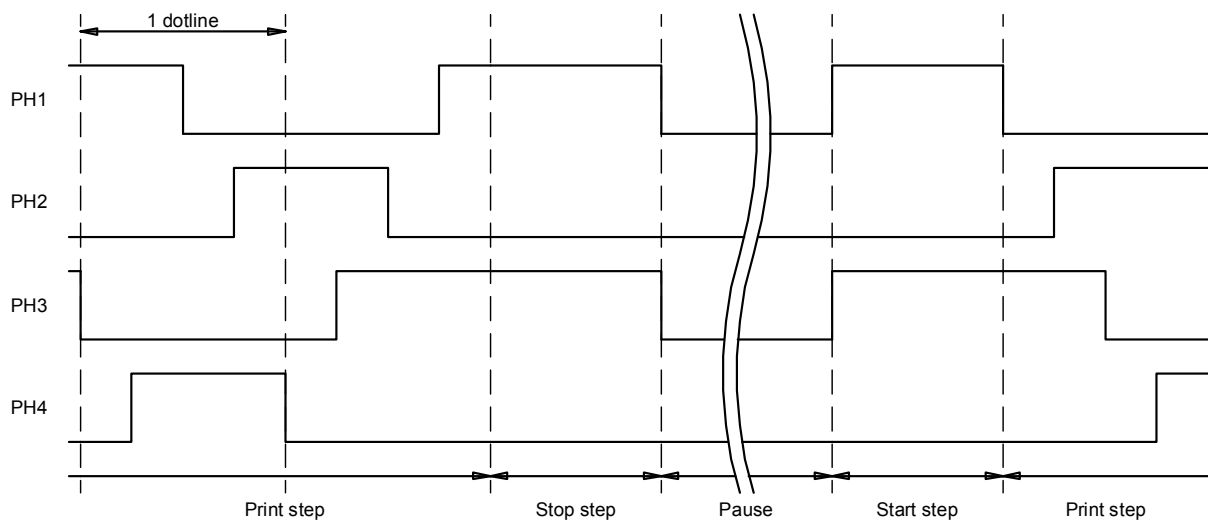

Figure 3-5 Motor Start/Stop Timing Chart

3.3.5 Motor Drive Method

Drive the motor by the following methods.

(1) Motor drive pulse rate

During paper feeding, the motor should be driven lower than the value obtained by equation (1).

Equation (1):

$$P_M = V_p \times 534 - 1339 \text{ (pps)}$$

P_M : Maximum motor drive pulse rate at V_p (pps)
However, 3200pps max.

V_p : Motor drive voltage (V)

Table 3-4 Maximum Motor Drive Pulse Rate

V_p	Maximum Motor Drive Pulse Rate
5.5 V	1598 pps
6.5 V	2132 pps
7.5 V	2666 pps
8.5 V	3200 pps
9.5 V	3200 pps

During paper feeding in backward, the motor should be driven lower than 960pps.

(2) Motor speed control

When driving the motor, the acceleration control is required to maintain the paper feed force of start up. If acceleration of the motor does not perform correctly, the motor may not be able to rotate normally if it has a heavy workload. Accelerate the speed sequentially up to the maximum motor drive pulse rate P_M according to the Table 3-5 Acceleration Steps.

Acceleration should be performed by the acceleration step time below, that is output the phase.

1. Drive the start step by $4291 \mu s$.
2. Drive the first step as same as acceleration step time at 1st acceleration step.
3. Drive the second step as same as acceleration step time at 2nd acceleration step.
4. Hereinafter, drive the "n"th step as same as acceleration step time at "n"th acceleration step.
5. After accelerating up to the maximum motor drive pulse rate P_M , drive the motor at a constant speed.

Available to print during acceleration.

Follow the procedures below if :

Unable to accelerate the speed for the reasons above even if following the Table 3-5.

The speed has been reduced at a certain speed and then accelerates the speed again.

The next step time after reducing the speed is the nearest acceleration step time, which should be longer than the previous acceleration step time and shortest.

(ex) In the case of Table 3-5, if the previous step time is $950 \mu s$, the next step should be the 11th acceleration step ($967 \mu s$).

Hereinafter, accelerate the speed sequentially up to the maximum motor drive pulse rate P_M according to Table 3-5.

Table 3-5 Acceleration Steps

Number of Steps	Drive Pulse Rate (pps)	Step Time (μs)	Number of Steps	Drive Pulse Rate (pps)	Step Time (μs)
Start	-	4291	49	2270	440
1	233	4291	50	2294	436
2	377	2652	51	2317	432
3	488	2048	52	2341	427
4	582	1719	53	2363	423
5	663	1507	54	2386	419
6	737	1357	55	2409	415
7	805	1243	56	2431	411
8	867	1153	57	2453	408
9	926	1080	58	2475	404
10	981	1019	59	2497	400
11	1034	967	60	2519	397
12	1084	923	61	2540	394
13	1132	883	62	2561	390
14	1178	849	63	2582	387
15	1222	818	64	2603	384
16	1265	790	65	2624	381
17	1307	765	66	2644	378
18	1347	742	67	2665	375
19	1386	721	68	2685	372
20	1424	702	69	2705	370
21	1462	684	70	2725	367
22	1498	668	71	2745	364
23	1533	652	72	2764	362
24	1568	638	73	2784	359
25	1602	624	74	2803	357
26	1635	612	75	2822	354
27	1668	600	76	2842	352
28	1700	588	77	2860	350
29	1731	578	78	2879	347
30	1762	568	79	2898	345
31	1792	558	80	2917	343
32	1822	549	81	2935	341
33	1851	540	82	2954	339
34	1880	532	83	2972	336
35	1909	524	84	2990	334
36	1937	516	85	3008	332
37	1964	509	86	3026	330
38	1992	502	87	3044	329
39	2018	495	88	3062	327
40	2045	489	89	3079	325
41	2071	483	90	3097	323
42	2097	477	91	3114	321
43	2123	471	92	3132	319
44	2148	466	93	3149	318
45	2173	460	94	3166	316
46	2198	455	95	3183	314
47	2222	450	96	3200	313
48	2246	445	-	-	-

(3) Preventing Overheat

To prevent the motor from overheating, the maximum continuous drive time and drive ratio are limited. Table 3-6 shows the Maximum Continuous Drive Time and Drive Ratio of the motor per print within 1m. Follow Table 3-6 shown below to set drive time and a pause time of the motor. Table 3-7 and Figure 3-8 show Drive Time and Paper Length at Temperature Rise of 50°C and 75°C.

Temperature rise of the motor is different according to the use conditions. (ambient temperature, designing the outer case etc.) Keep the temperature of the motor outer case, 100°C or lower. Verify the performance with your actual device.

Table 3-6 Maximum Continuous Drive Time and Drive Ratio

Drive Pulse Rate (pps)	Maximum Continuous Drive Time (sec)	Motor Drive Voltage Vp (V)				
		9.5V ≥ Vp > 8.5V	8.5V ≥ Vp > 7.5V	7.5V ≥ Vp > 6.5V	6.5V ≥ Vp > 5.5V	5.5V
		Drive Ratio				
320 ~ 480	100	45%	45%	50%	55%	60%
480 ~ 640	67	45%	45%	50%	55%	60%
640 ~ 800	50	45%	45%	50%	55%	60%
800 ~ 960	40	45%	45%	50%	55%	60%
960 ~ 1120	33	45%	45%	50%	55%	60%
1120 ~ 1280	29	45%	45%	50%	55%	60%
1280 ~ 1440	25	45%	45%	50%	55%	60%
1440 ~ 1600	22	45%	45%	50%	55%	60%
1600 ~ 1760	20	45%	45%	50%	55%	-
1760 ~ 1920	18	45%	45%	50%	55%	-
1920 ~ 2080	17	45%	45%	50%	55%	-
2080 ~ 2240	15	45%	45%	50%	55%	-
2240 ~ 2400	14	45%	45%	50%	-	-
2400 ~ 2560	13	45%	45%	50%	-	-
2560 ~ 2720	13	45%	45%	50%	-	-
2720 ~ 2880	12	45%	45%	-	-	-
2880 ~ 3040	11	45%	45%	-	-	-
3040 ~ 3200	11	45%	50%	-	-	-
3200	10	45%	50%	-	-	-

- : Unusable

Set the Drive Pulse Rate according to "3.3.5 Motor Drive Method".

$$\text{Drive Ratio(\%)} = \frac{\text{Drive Time}}{\text{Drive Time} + \text{Pause Time}} \times 100(\%)$$

Table 3-7 Drive Time and Paper Length at Temperature Rise 50°C

Drive Pulse Rate (pps)	Motor Drive Voltage Vp (V)									
	9.5V ≥ Vp > 8.5V		8.5V ≥ Vp > 7.5V		7.5V ≥ Vp > 6.5V		6.5V ≥ Vp > 5.5V		5.5V	
	min	(m or longer)	min	(m or longer)	min	(m or longer)	min	(m or longer)	min	(m or longer)
320 ~ 480	5.1	3.1	5.2	3.1	5.1	3.1	4.7	2.8	4.9	2.9
480 ~ 640	5.1	4.6	5.2	4.7	5.1	4.6	4.8	4.3	5.0	4.5
640 ~ 800	5.0	6.0	5.1	6.2	5.1	6.1	4.8	5.8	5.2	6.2
800 ~ 960	4.9	7.4	5.1	7.7	5.1	7.7	4.9	7.3	5.3	8.0
960 ~ 1120	4.8	8.7	5.1	9.1	5.1	9.2	4.9	8.9	5.4	9.8
1120 ~ 1280	4.8	10.0	5.0	10.5	5.1	10.8	5.0	10.5	5.6	11.7
1280 ~ 1440	4.7	11.3	5.0	12.0	5.1	12.3	5.1	12.1	5.7	13.7
1440 ~ 1600	4.6	12.5	4.9	13.3	5.1	13.9	5.1	13.8	5.8	15.7
1600 ~ 1760	4.6	13.7	4.9	14.7	5.1	15.4	5.2	15.5	-	-
1760 ~ 1920	4.5	14.8	4.9	16.0	5.2	17.0	5.2	17.2	-	-
1920 ~ 2080	4.4	15.9	4.8	17.4	5.2	18.6	5.3	18.9	-	-
2080 ~ 2240	4.3	16.9	4.8	18.6	5.2	20.1	5.3	20.7	-	-
2240 ~ 2400	4.3	17.9	4.7	19.9	5.2	21.7	-	-	-	-
2400 ~ 2560	4.2	18.8	4.7	21.1	5.2	23.3	-	-	-	-
2560 ~ 2720	4.1	19.7	4.7	22.4	5.2	24.8	-	-	-	-
2720 ~ 2880	4.0	20.6	4.6	23.6	-	-	-	-	-	-
2880 ~ 3040	4.0	21.4	4.6	24.7	-	-	-	-	-	-
3040 ~ 3200	3.9	22.2	4.5	25.9	-	-	-	-	-	-
3200	3.8	22.9	4.5	27.0	-	-	-	-	-	-

- : Unusable

Set the Drive Pulse Rate according to "3.3.5 Motor Drive Method".

Table 3-8 Drive Time and Paper Length at Temperature Rise 75°C

Drive Pulse Rate (pps)	Motor Drive Voltage Vp (V)									
	9.5V ≥ Vp > 8.5V		8.5V ≥ Vp > 7.5V		7.5V ≥ Vp > 6.5V		6.5V ≥ Vp > 5.5V		5.5V	
	min	(m or longer)	min	(m or longer)	min	(m or longer)	min	(m or longer)	min	(m or longer)
320 ~ 480	12.1	7.3	12.9	7.8	12.1	7.3	9.2	5.5	9.9	6.0
480 ~ 640	11.9	10.7	12.9	11.6	12.4	11.2	10.0	9.0	11.3	10.2
640 ~ 800	11.7	14.0	12.9	15.5	12.7	15.2	10.7	12.9	12.7	15.3
800 ~ 960	11.5	17.3	12.9	19.3	13.0	19.4	11.5	17.2	14.1	21.2
960 ~ 1120	11.3	20.3	12.8	23.1	13.2	23.8	12.2	22.0	15.5	28.0
1120 ~ 1280	11.1	23.3	12.8	26.9	13.5	28.4	13.0	27.2	16.9	35.6
1280 ~ 1440	10.9	26.2	12.8	30.7	13.8	33.2	13.7	32.9	18.4	44.0
1440 ~ 1600	10.7	28.9	12.8	34.5	14.1	38.1	14.4	39.0	19.8	53.3
1600 ~ 1760	10.5	31.5	12.8	38.3	14.4	43.2	15.2	45.6	-	-
1760 ~ 1920	10.3	34.0	12.8	42.1	14.7	48.4	15.9	52.6	-	-
1920 ~ 2080	10.1	36.3	12.7	45.9	15.0	53.8	16.7	60.0	-	-
2080 ~ 2240	9.9	38.6	12.7	49.6	15.2	59.4	17.4	67.9	-	-
2240 ~ 2400	9.7	40.7	12.7	53.3	15.5	65.2	-	-	-	-
2400 ~ 2560	9.5	42.7	12.7	57.1	15.8	71.1	-	-	-	-
2560 ~ 2720	9.3	44.6	12.7	60.8	16.1	77.2	-	-	-	-
2720 ~ 2880	9.1	46.3	12.6	64.5	-	-	-	-	-	-
2880 ~ 3040	8.9	47.9	12.6	68.2	-	-	-	-	-	-
3040 ~ 3200	8.7	49.4	12.6	71.9	-	-	-	-	-	-
3200	8.5	50.8	12.6	75.6	-	-	-	-	-	-

- : Unusable

Set the Drive Pulse Rate according to "3.3.5 Motor Drive Method".

3.3.6 Motor Drive Precautions

- Using the motor drive circuit other than the circuit shown in "Section 3.3.2 Sample Drive Circuit" may not ensure the specified efficiency.
- To prevent degradation in the print quality due to the backlash of the paper drive system, feed the thermal paper for 48 steps or more at the initialization, at a time after setting/releasing the platen unit, a time after feeding the thermal paper backward and a time after cutting with a paper cutter. During this time, drive the motor with constant speed at the 1st acceleration step.
- When printing, change the motor drive pulse rate depending on the operational conditions such as voltage, temperature, and the number of activated dots. (See "CHAPTER 5 PRINT DRIVE METHOD" for details.)
- When printing, change the motor drive pulse rate so that the activation pulse width of the thermal head does not exceed the sum of the two-step times of the motor. (See "CHAPTER 5 PRINT DRIVE METHOD" for details.)
- Do not perform continuous printing to prevent the motor from overheating. Refer to Chapter 3 "Motor Drive Method" to set a pause time.
- Surface of the thermal paper may get scratched by backward feed. The backward feed may cause paper skew and jams depending on the paper roll layout and designing of the paper holder. Be sure to confirm performance with your product before using the backward feed.
- Do not print intermittently. (Do not repeat printing and stopping in a short interval.)
If doing so, print quality may be decreased due to unevenness of the paper feed pitch.
- Always perform the start and the stop steps for both character print and bit image print.
- For the motor stop, a minimum one dot line of motor feed is required from the step that thermal head was activated. If the motor is stopped at the step that the thermal head has been activated, paper feed difficulty may be caused due to sticking of the thermal paper to the thermal head.
- Sound and vibration during printing vary depending on the motor drive pulse rate. Verify the performance with your actual device.

3.4 THERMAL HEAD

The thermal head consists of heat elements and a thermal head driver that drives and controls the heat elements. For the print data entered through the DI, print is "High" and non print is "low". The data from the DI is transferred to the shift register at the rising edge of the CLK signal. The data is stored into the latch register by making /LAT signal "Low" after one line data is transferred. The heat elements are activated by making DST signal "High" in accordance with the stored print data.

Simultaneously activated dots is 45 dots.

3.4.1 Structure of the Thermal Head

Figure 3-6 shows the thermal head block diagram when driving the printer.

Table 3-9 shows the relationship between DST and activated heating elements.

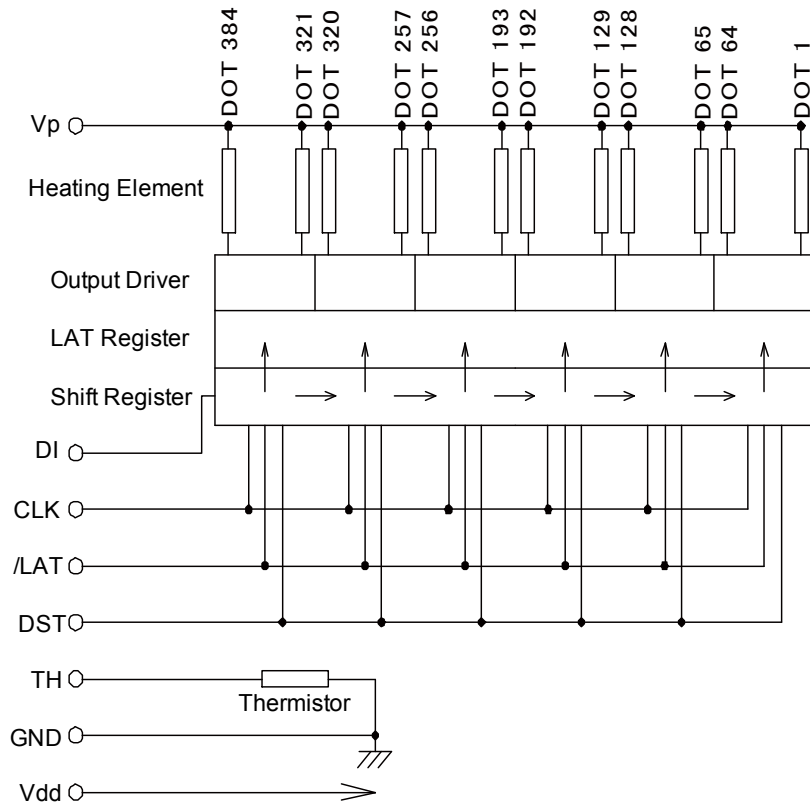

Figure 3-6 Thermal Head Block Diagram

Table 3-9 DST and Heating Elements

Block	DST Number	Heating Element Number	Dots / DST
1	DST	1 to 64	384
2		65 to 128	
3		129 to 192	
4		193 to 256	
5		257 to 320	
6		321 to 384	

3.4.2 Print Position of the Data

384-bit data (#1 to #384) transferred through DI are printed when driving the printer as shown in Figure 3-7.

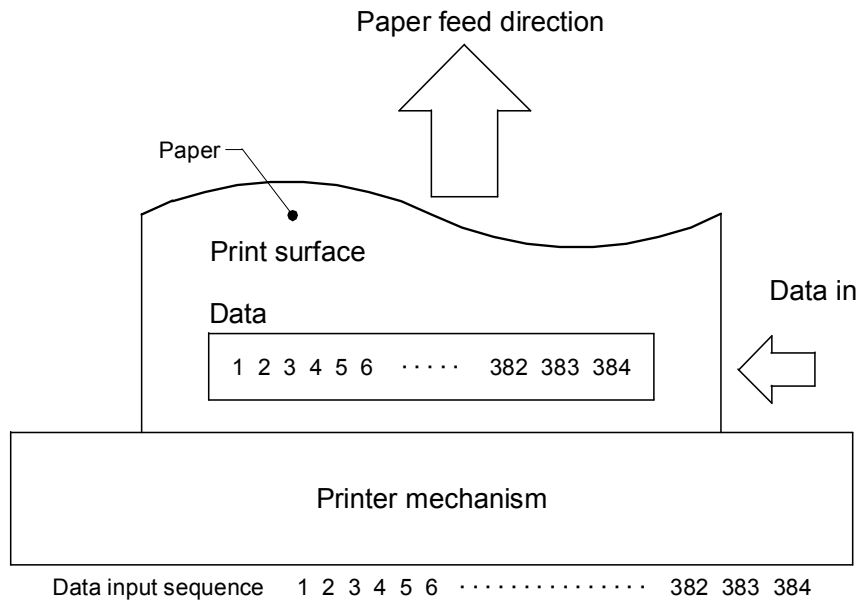

Figure 3-7 Transfer Data and Print Position

3.4.3 Electrical Characteristics of Thermal Head

Table 3-10 shows electrical characteristics of thermal head.

Table 3-10 Electrical Characteristics of Thermal Head

Vdd: 3.0 V to 3.6 V

(Temperature : 25 °C)

Item	Symbol	Conditions	Rated Value			Unit
			Min.	Typ.	Max.	
Thermal head heat element resistance	R_H		162	180	198	Ω
Thermal head drive voltage	V_p		5.5	—	9.5	V
Thermal head drive current	I_P	The number of simultaneously activated dots = 45	—	—	2.64	A
Logic voltage	Vdd		3.0	3.3	3.6	V
Logic current	I_{dd}	$f_{DI}=1/2f_{CLK}$	—	—	15.0	mA
Input voltage	High	V_{IH} CLK, DI, /LAT, DST	$0.8 \times V_{dd}$	—	Vdd	V
	Low	V_{IL} CLK, DI, /LAT, DST	0	—	$0.2 \times V_{dd}$	V
DI input current	High	I_{IH} DI $V_{IH} = V_{dd}$	—	—	0.5	μA
	Low	I_{IL} DI $V_{IL} = 0V$	—	—	-0.5	μA
DST input current (High active)	High	I_{IH} DST $V_{IH} = V_{dd}$	—	—	210	μA
	Low	I_{IL} DST $V_{IL} = 0V$	—	—	-30	μA
CLK input current	High	I_{IH} CLK $V_{IH} = V_{dd}$	—	—	1.0	μA
	Low	I_{IL} CLK $V_{IL} = 0V$	—	—	-1.0	μA
/LAT input current	High	I_{IH} /LAT $V_{IH} = V_{dd}$	—	—	1.0	μA
	Low	I_{IL} /LAT $V_{IL} = 0V$	—	—	-1.0	μA
CLK frequency	f_{CLK}		—	—	8.0	MHz
CLK pulse width	$t1^{*1}$		47.5	—	—	ns
DI setup time	$t2^{*1}$		40	—	—	ns
DI hold time	$t3^{*1}$		40	—	—	ns
/LAT setup time	$t4^{*1}$		120	—	—	ns
/LAT pulse width	$t5^{*1}$		120	—	—	ns
/LAT hold time	$t6^{*1}$		70	—	—	ns
DST setup time	$t7^{*1}$		300	—	—	ns
/LAT wait time	$t8^{*1,*2}$		8000	—	—	ns

*1: See the timing chart.

*2: If MIN at "/LAT wait time" in the table cannot be secured, it may cause V_p voltage fluctuations.

3.4.4 Timing Chart

Figure 3-8 shows a thermal head drive timing chart.

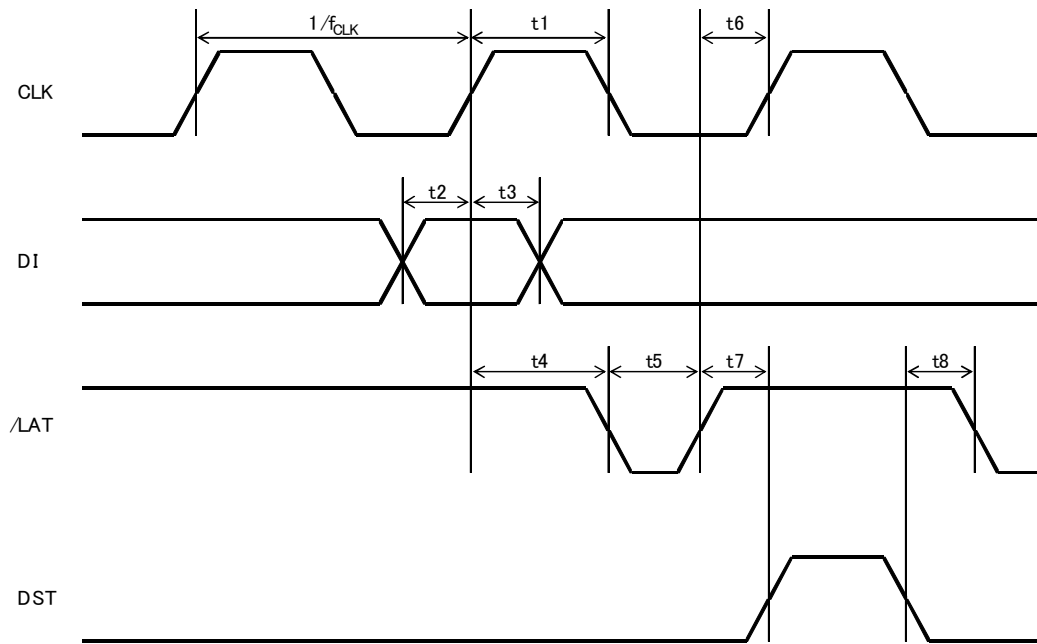

Figure 3-8 Thermal Head Drive Timing Chart

3.4.5 Thermal Head Heat Element Resistance

Table 3-11 shows resistance of the thermal head heat element of the printer.

Table 3-11 Thermal Head Heat Element Resistance

Thermal Head Heat Element Resistance
162.0 Ω to 198.0 Ω

3.4.6 Maximum Current Consumption

Since the maximum current consumption may reach the values calculated using equation (2) when the thermal head is driven, the number of simultaneously activated dots should be determined not to exceed power supply capacity. Also, allowable current for the cable material and the voltage drop on the cable should be cared well.

Equation (2):

$$I_P = \frac{N_{SA} \times V_p}{R_{H \min}}$$

- I_P : Maximum current consumption (A)
- N_{SA} : Number of simultaneously activated dots
- V_p : Thermal head drive voltage (V)
- $R_{H \min}$: Minimum thermal head heat element resistance 162.0 (Ω)

3.5 CONTROLLING THE ACTIVATION PULSE WIDTH FOR THERMAL HEAD

To execute high quality printing using the printer, the activation pulse width according to printer use condition must be used. Control printing with the activation pulse width calculated by the following sequence. Printing at too high voltage or too long activation pulse width may shorten the life of the thermal head.

3.5.1 Calculation of Activation Pulse Width

Each value can be calculated according to the steps in Section 3.5.2 to 3.5.6 and the activation pulse width "t" can be calculated by substituting each value into the equation (3).

Equation (3):

$$t = \frac{E \times R}{V^2} \times C$$

t	:	Thermal head activation pulse width (ms)	
E	:	Printing energy (mJ)	See section 3.5.2
R	:	Adjusted resistance (Ω)	See section 3.5.3
V	:	Adjusted voltage (V)	See section 3.5.4
C	:	Thermal head activation pulse cycle coefficient	See section 3.5.6

3.5.2 Calculation of Printing Energy

The printing energy "E" can be calculated using equation (4) as the appropriate printing energy is different depending on each specified thermal paper and the temperature of the thermal head.

Equation (4):

$$E = E_{25} - T_C \times (T_X - 25)$$

E_{25}	:	Standard printing energy (mJ)	See Table 3-12
T_C	:	Temperature coefficient	See Table 3-12
T_X	:	Temperature detected by thermistor ($^{\circ}\text{C}$) *	

*: Measure the temperature using the resistance of the built-in thermistor on the thermal head.
For the thermistor resistance value at T_X ($^{\circ}\text{C}$), see "3.5.8 Temperature Characteristics of Thermistor".

Table 3-12 Standard Printing Energy and Temperature Coefficient

Thermal paper		Standard Printing Energy (mJ)	Temperature Coefficient
Nippon Paper	TF50KS-E2D	0.2867	0.003430
Jujo Thermal	AF50KS-E	0.3048	0.003365
Jujo Thermal	AP45KS-NP	0.3321	0.002989
Mitsubishi Hi-Tech Paper	F5041	0.3036	0.003555
Papierfabrik August Koehler AG	KT55F20	0.2810	0.002834

3.5.3 Adjustment of Thermal Head Resistance

The adjusted resistance "R" can be calculated using equation (5) to adjust the thermal head resistance as a voltage drop is caused by wiring resistance.

Equation (5):

$$R = \frac{(R_H + R_i + (R_C + r_c) \times N_{SA})^2}{R_H}$$

R_H	:	Thermal head heat element resistance	180 (Ω)
R_i	:	Wiring resistance in the thermal head	9 (Ω)
R_C	:	Common terminal wiring resistance in the thermal head	0.278 (Ω)
r_c	:	Wiring resistance between Vp and GND (Ω) *1	
N_{SA}	:	The number of simultaneously activated dots	

*1: The resistance is a serial resistance of the wire and switching circuit of relay between control terminal and power supply.

3.5.4 Adjustment of Thermal Head Drive Voltage

The adjusted voltage "V" can be calculated using equation (6) as the printing density changes by the difference of the thermal head drive voltage.

Equation (6):

$$V = 1.124 \times V_p - 1.182$$

V_p	:	Thermal head drive voltage (V)
-------	---	--------------------------------

3.5.5 Setting of Activation Pause Time

In order to protect the thermal head heat elements, when the same heat element dots are activated continuously on the successive dot line, determine the activation pulse cycle (the time from the start of the preceding activation to the start of the current activation) which meets equation (7) to secure the pause time.

Equation (7):

$$W > t + 500 (\mu s)$$

W	:	The activation cycle (μs) *1
-----	---	-------------------------------------

*1: The activation cycle W is the driving time of the printer drive motor for 2 steps (one-half dot line).

3.5.6 Adjustment by Thermal Head Activation Pulse Cycle

The thermal head activation pulse cycle coefficient "C" can be calculated using equations (8) as the printing density varies by the thermal head activation pulse cycle (equivalent for motor drive pulse rate).

Equation (8):

$$C = 1 - \frac{2230 \times Vp - 6429}{(Vp - 3.78) \times (W' + 2420) + 2100}$$

W' : The time between the beginning of the last thermal head activation and the beginning of present thermal head activation (μs)

To calculate the activation pulse width t1 for the half dot line 2 (at step 3 and 4), W'1 shown in the figure below should be set as W' defined at Equation (8).

To calculate the activation pulse width t2 for the half dot line 5 (at step 9 and 10), W'2 shown in the figure below should be set as W' defined at Equation (8).

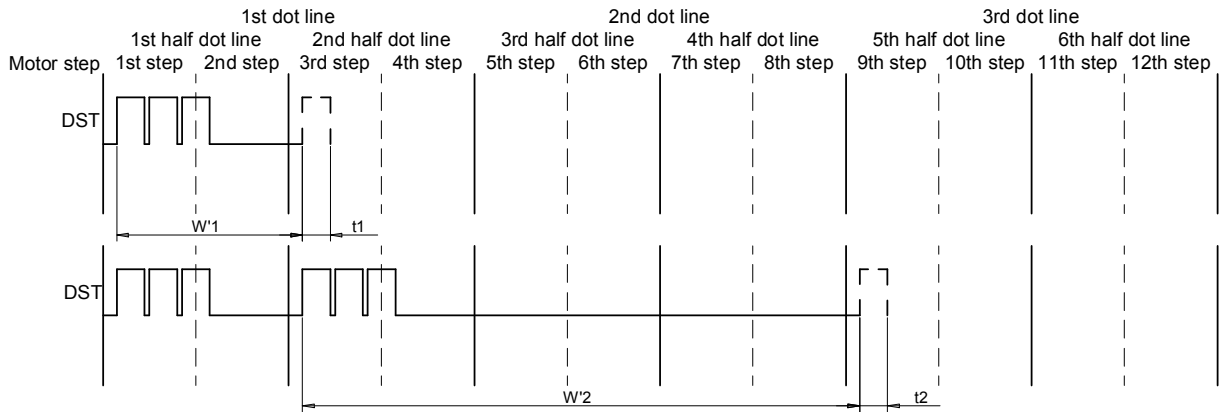

Figure 3-9 the Time Between the Beginning of the Last Thermal Head Activation and the Beginning of Present Thermal Head Activation (W')

3.5.7 Calculation Sample for the Activation Pulse Width

Table 3-13 lists the calculation samples of the activation pulse width calculated using equation (3) and the values obtained using equations (4) to (6) and (8).

Table 3-13 Activation Pulse Width

Unit : ms

Vp [V]	Tx [°C]	Motor Drive Pulse Rate [pps]								
		640	960	1280	1600	1920	2240	2560	2880	3200
5.5	-10	1.830	1.495	1.277	-	-	-	-	-	-
	0	1.676	1.369	1.169	-	-	-	-	-	-
	10	1.521	1.243	1.062	-	-	-	-	-	-
	20	1.367	1.117	0.954	-	-	-	-	-	-
	30	1.213	0.991	0.846	-	-	-	-	-	-
	40	1.058	0.865	0.739	-	-	-	-	-	-
	50	0.904	0.739	0.631	-	-	-	-	-	-
	60	0.750	0.612	0.523	-	-	-	-	-	-
6.5	-10	1.298	1.071	0.921	0.813	0.733	-	-	-	-
	0	1.189	0.981	0.843	0.745	0.671	-	-	-	-
	10	1.079	0.891	0.765	0.676	0.609	-	-	-	-
	20	0.970	0.800	0.688	0.608	0.548	-	-	-	-
	30	0.860	0.710	0.610	0.539	0.486	-	-	-	-
	40	0.751	0.620	0.533	0.470	0.424	-	-	-	-
	50	0.641	0.529	0.455	0.402	0.362	-	-	-	-
	60	0.532	0.439	0.377	0.333	0.300	-	-	-	-
7.5	-10	0.955	0.793	0.684	0.605	0.546	0.500	0.463	-	-
	0	0.875	0.726	0.626	0.554	0.500	0.458	0.424	-	-
	10	0.794	0.659	0.568	0.503	0.454	0.416	0.385	-	-
	20	0.714	0.592	0.511	0.452	0.408	0.373	0.346	-	-
	30	0.633	0.525	0.453	0.401	0.362	0.331	0.307	-	-
	40	0.553	0.459	0.395	0.350	0.316	0.289	0.268	-	-
	50	0.472	0.392	0.338	0.299	0.270	0.247	0.229	-	-
	60	0.391	0.325	0.280	0.248	0.224	0.205	0.190	-	-
8.5	-10	0.729	0.607	0.524	0.465	0.420	0.385	0.356	0.333	0.314
	0	0.668	0.556	0.480	0.426	0.384	0.352	0.326	0.305	0.287
	10	0.606	0.505	0.436	0.386	0.349	0.320	0.296	0.277	0.261
	20	0.545	0.453	0.392	0.347	0.314	0.287	0.266	0.249	0.234
	30	0.483	0.402	0.348	0.308	0.278	0.255	0.236	0.221	0.208
	40	0.422	0.351	0.303	0.269	0.243	0.222	0.206	0.193	0.181
	50	0.360	0.300	0.259	0.230	0.207	0.190	0.176	0.165	0.155
	60	0.299	0.249	0.215	0.190	0.172	0.158	0.146	0.136	0.129
9.5	-10	0.574	0.479	0.414	0.367	0.332	0.304	0.282	0.264	0.248
	0	0.525	0.438	0.379	0.336	0.304	0.279	0.258	0.241	0.227
	10	0.477	0.398	0.344	0.305	0.276	0.253	0.234	0.219	0.206
	20	0.428	0.358	0.309	0.274	0.248	0.227	0.211	0.197	0.185
	30	0.380	0.317	0.274	0.243	0.220	0.202	0.187	0.175	0.165
	40	0.332	0.277	0.239	0.212	0.192	0.176	0.163	0.152	0.144
	50	0.283	0.236	0.205	0.181	0.164	0.150	0.139	0.130	0.123
	60	0.235	0.196	0.170	0.151	0.136	0.125	0.116	0.108	0.102
9.5	-10	0.187	0.156	0.135	0.120	0.108	0.099	0.092	0.086	0.081

(Note) The table above is applicable under the following condition:

- Use of thermal paper "TF50KS-E2D"
- Vp and GND wiring resistance : $r_c = 0$
- The number of simultaneously activated dots : $N_{SA} = 45$

3.5.8 Temperature Characteristics of Thermistor

Calculate the resistance of the thermistor (R_x) at the operating temperature T_x ($^{\circ}\text{C}$) using the following equation (9). Variation of resistance by temperature is shown in Figure 3-11 and Table 3-14.

Equation (9):

$$R_x = R_{25} \times \text{EXP} \left\{ B \times \left(\frac{1}{273 + T_x} - \frac{1}{298} \right) \right\}$$

- R_x : Resistance at T_x $^{\circ}\text{C}$ (Ω)
- R_{25} : Resistance at 25 $^{\circ}\text{C}$ $30\text{k}\Omega \pm 5\%$
- B : B value $3950\text{K} \pm 3\%$
- T_x : Temperature detected by thermistor ($^{\circ}\text{C}$)
- EXP (A) : The "A" th power of natural logarithm e (2.71828)

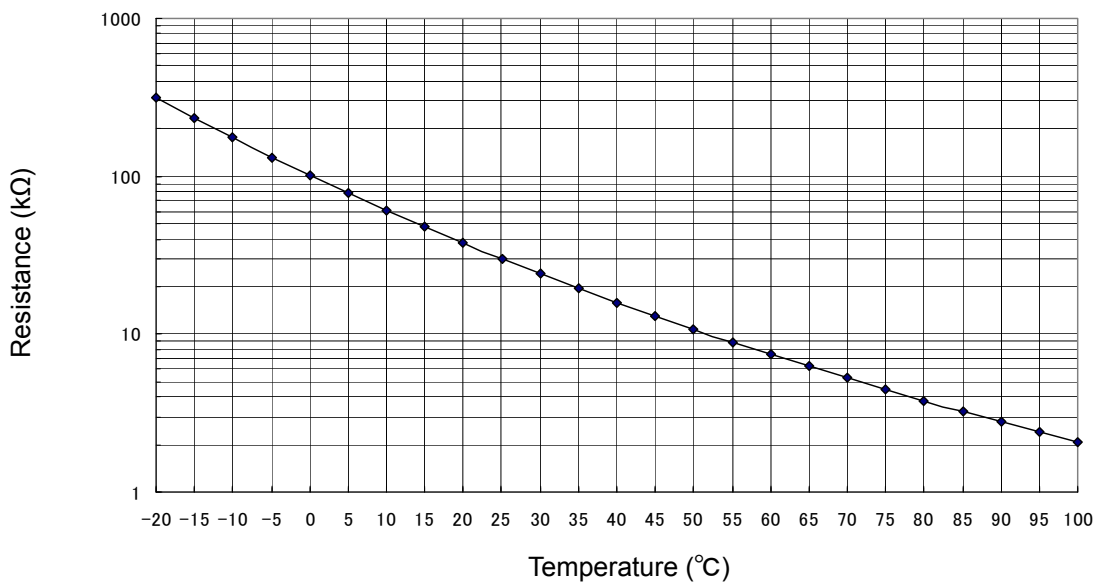

Figure 3-10 Temperature Characteristics of the Thermistor

Table 3-14 Temperature Characteristics of the Thermistor

Temperature (°C)	Thermistor Resistance (kΩ)
-10	175.07
-5	132.29
0	100.99
5	77.85
10	60.57
15	47.53
20	37.61
25	30.00
30	24.11
35	19.51
40	15.89
45	13.03
50	10.75
55	8.92
60	7.45
65	6.25
70	5.27
75	4.47
80	3.80
85	3.25
90	2.79
95	2.41
100	2.09

3.5.9 Detecting Abnormal Temperature of the Thermal Head

To protect the thermal head and to ensure personal safety, abnormal temperature of the thermal head must be detected by both hardware and software as follows:

(1) Detecting abnormal temperatures by software

Design software that will deactivate the heat elements if the thermal head thermistor (TH) detects a temperature higher than 70°C (thermistor resistance $R_{TH} \leq 5.27 \text{ k}\Omega$), and reactivate the heat elements when a temperature lower than 60°C ($R_{TH} \leq 7.45 \text{ k}\Omega$) is detected. If the thermal head continues to be activated at a temperature higher than 70°C, the life of the thermal head may be shortened significantly.

(2) Detecting abnormal temperatures by hardware

If the thermal head continues to be activated by malfunction of the control unit (CPU), the software for detecting abnormal temperatures may not function properly, resulting in overheating of the thermal head. Overheating of the thermal head not only may damage the thermal head but also may cause smoke, fire and burn injuries. Always use hardware together with software for detecting abnormal temperatures to ensure personal safety. (If the control unit malfunctions, it may be impossible to prevent damage on the thermal head even if an abnormal temperature is detected by hardware.).

Using a window comparator circuit or similar sensor, design hardware that detects the following abnormal conditions:

- (a) Overheating of the thermal head
(approximately 100°C or higher ($R_{TH} \leq 2.09 \text{ k}\Omega$))
- (b) Faulty thermistor connection (the thermistor may be open or short-circuited).

If abnormal condition is detected, immediately turn off the power supply. Reactivate the heat elements after they have returned to normal.

3.6 OUT-OF-PAPER SENSOR

The printer has a built-in out-of-paper sensor (reflection type photo interrupter) to detect whether paper is present or not. An external circuit should be designed so that it detects output from the out-of-paper sensor and does not activate the thermal head and motor when there is no paper. Doing not so may cause damage to the thermal head or platen roller or shorten the life of the thermal head significantly. If the motor is driven when there is no paper, a load is put on the paper drive system and the life of the printer may be shortened significantly.

Table 3-15 shows about the out-of-paper sensor used for this printer.

Table 3-15 Out-of-paper Sensor

Item	Specification
Type	NJL5902R-2
Manufacturer	New Japan Radio Co.,Ltd

Figure 3-11 shows sample external circuit of the out-of-paper sensor.

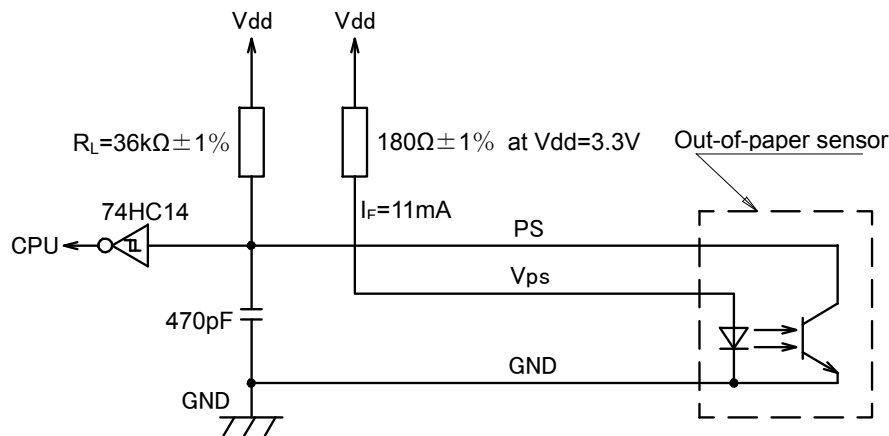

*: The PS signal is "High" when there is no paper.

Figure 3-11 Sample External Circuit of the Out-of-paper Sensor

3.6.1 Precautions for the Out-of-Paper Sensor

- The out-of-paper sensor may generate instantaneous abnormal signal. Design the firmware in order to prevent malfunction due to the abnormal signal. (Recommended frequency: detecting twice every 10 ms.)

CHAPTER 4 CONNECTING TERMINALS

4.1 RECOMMENDED CONNECTOR FOR EXTERNAL CIRCUITS

Use the recommended connectors listed in Table 4-1 to connect the printer connecting terminals firmly to the external circuits.

Table 4-1 Recommended Connectors

Number of Terminals	Recommended Connectors
24	MOLEX INC: 0545502471 (Right angle type : Top contact, Gold plated)

4.2 CONNECTING TERMINALS

Figure 4-1 shows the terminal configuration of the connecting terminals and Table 4-2 shows terminal assignments of the connecting terminals.

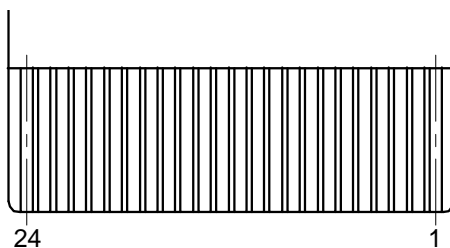

Figure 4-1 Connecting Terminals

Table 4-2 Terminal Assignments of the Connecting Terminal

Terminal No.	Terminal Name	Function
1	PS	Output of the out-of-paper sensor (Photo-transistor collector)
2	G _{PS}	GND of the out-of-paper sensor (LED cathode, photo-transistor emitter)
3	V _{PS}	Power supply of the out-of-paper sensor (LED anode)
4	V _p	Thermal head drive power supply
5	V _p	Thermal head drive power supply
6	V _p	Thermal head drive power supply
7	DI	Print data input (serial input)
8	CLK	Synchronizing for print data transfer
9	GND	GND
10	GND	GND
11	GND	GND
12	V _{dd}	Logic power supply
13	DST	Thermal head print activation instruction
14	TH	Thermistor
15	GND	GND
16	GND	GND
17	GND	GND
18	/LAT	Print data latch (memory storage)
19	V _p	Thermal head drive power supply
20	V _p	Thermal head drive power supply
21	A	Motor drive
22	/A	Motor drive
23	B	Motor drive
24	/B	Motor drive

CHAPTER 5 PRINT DRIVE METHOD

5.1 MOTOR AND THERMAL HEAD DRIVE METHOD

The motor and the thermal head must be driven at the same time for printing.

The printer uses the thermal head with heat elements which size is a half-dot size of the feed direction. One dot is, therefore, composed of two of the half dots. The motor feeds the thermal paper for one dot line with four steps. In order to print one dot line, feed the thermal paper for four steps and activate the thermal head in every two step.

Figure 5-1 shows a divided print timing chart.

1st dot line shows a timing chart for using three divisions printing.

2nd dot line shows a timing chart for using batch printing.

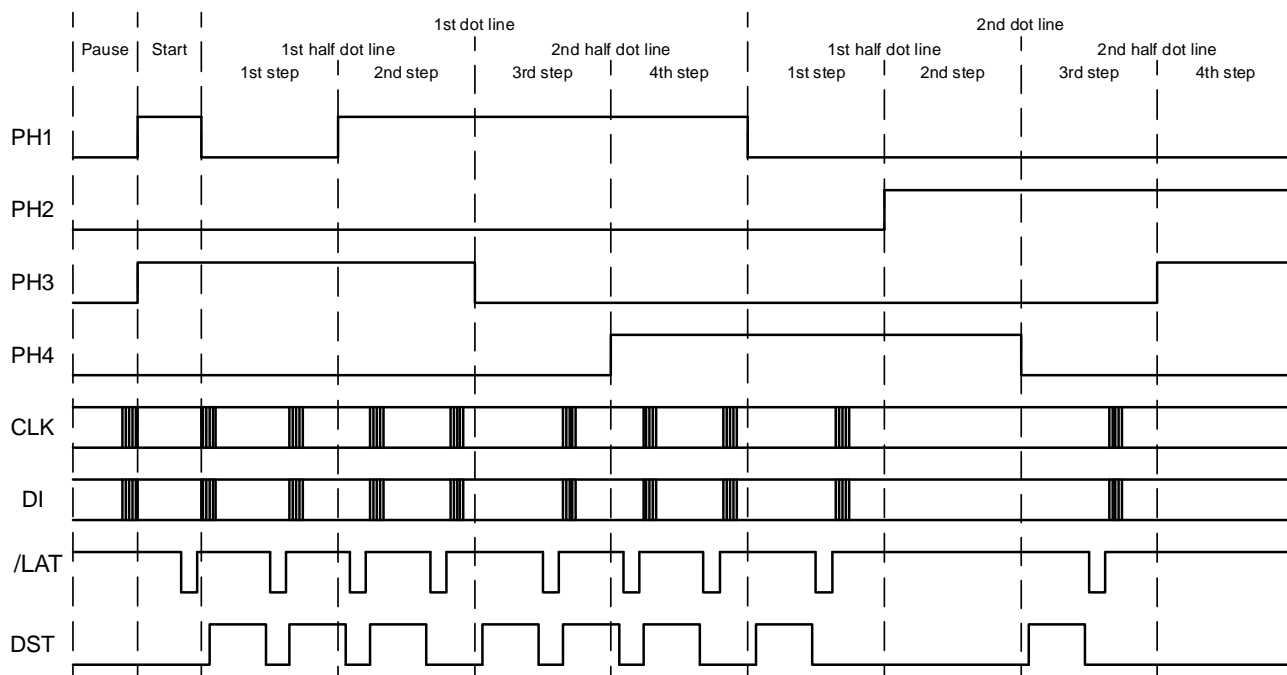

Figure 5-1 Divided Print Timing Chart Sample

The divided printing method is described below (See Figure 5-1):

(1) Pause state

Inactivate the motor and always make DST signal of the thermal head "Low".

(2) Start step

Excite the motor by the same phase which is output just before the motor stops.

(3) 1st dot line

Activate the thermal head once every 2 steps of the motor drive signal. Configure 1 dot line by 4 steps of the motor drive signal.

At the 1st step of the motor drive signal, start activation of the thermal head by synchronized the DST signal and printing the 1st half dot line at the 1st dot line by DST.

After 1st step of the motor drive signal is completed, input the 2nd step of the motor drive signal. (It is not necessary to synchronize the activation of the thermal head.)

After printing the 1st half dot line at the 1st dot line, the 3rd step of the motor drive signal, start activation of the thermal head by synchronized the DST signal and printing the 2nd half dot line at the 1st dot line by DST..

After 3rd step of the motor drive signal is completed, input the 4th step of the motor drive signal. (It is not necessary to synchronize the activation of the thermal head.)

Input the DST signal after transferring the data which is printed into the "SHIFT REGISTER" in the thermal head. And latch to "LATCH REGISTER" of the thermal head by inputting the /LAT signal.

(4) Procedures that follows the 2nd dot line

Drive the motor in the same way as the way for the 1st dot line. Repeat the motor driving and thermal head activation.

5.2 THERMAL HEAD DIVISION DRIVE METHOD

Logical blocks are predetermined so that number of dots of the physical block does not exceed the specified maximum number of the activating dots for every 1 dot line printing. Logical blocks are predetermined for every 1 dot line printing.

The maximum current consumption can be controlled within a constant value.

The thermal head in the printer can be driven with one DST signal. The number of the simultaneously activated dots should be 45 dots or less as the physical block.

5.3 PRECAUTIONS FOR PRINT DRIVE

- When using one division printing, a pause time between thermal head activations of the same heat element shall be secured more than 0.5ms.
- The number of the maximum thermal head division in a half dot line should be 9 or lower to maintain print quality. The number of the simultaneously activated dots should be 45 dots or less.

CHAPTER 6 OUTER CASE DESIGN GUIDE

6.1 FIXING THE PRINTER MAIN BODY

6.1.1 How to Mount the Printer Main Body

Figure 6-1 shows dimensions for positioning and fixing the printer main body.

- Holes #1 to #2 must be used for positioning the printer main body. Design bosses on the outer case to position the printer main body for the positioning holes #1 and #2. The height of the bosses on the outer case must be 1.5mm (max.).
- Screw up holes A and B.

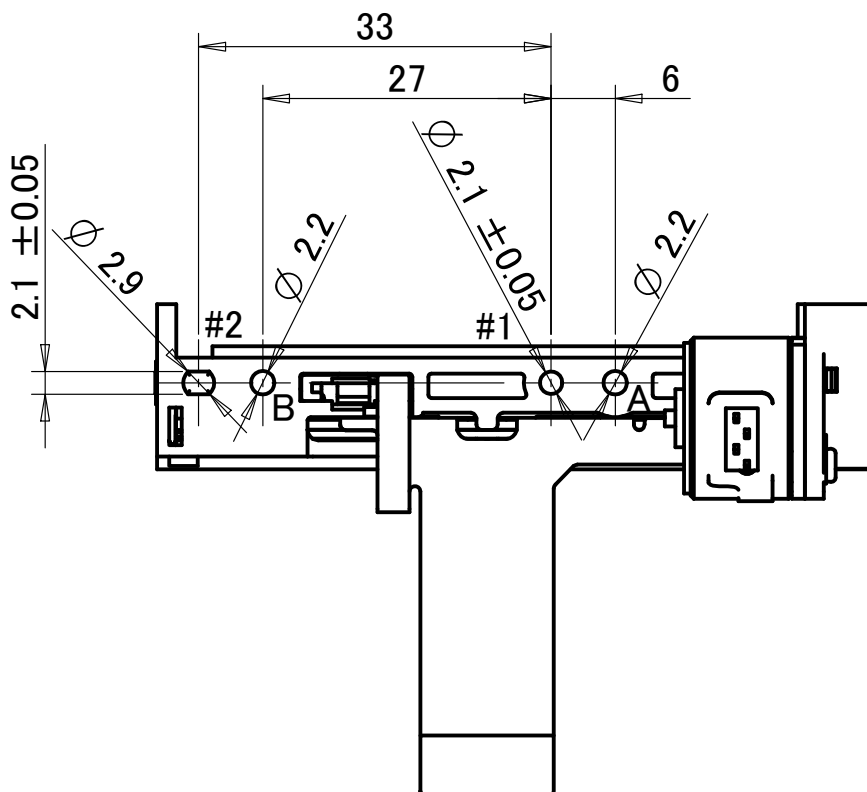

Unit : mm
General tolerance : ± 0.1

Figure 6-1 Dimensions for Positioning and Fixing the Printer Main Body

6.1.2 Recommended Screws

- JIS B1111 M2.0 cross-recessed pan head machine screw

6.1.3 Precautions for Fixing the Printer Main Body

- Prevent from excessive stress, deformation, and torsion when fixing the printer. Otherwise, poor printing quality, paper skewing, paper jamming, and noise during printing may be occur.
- The printer main body to be mounted on a flat surface and prevent from vibration.
- Connect the Frame Ground (FG) to Signal Ground (GND) through approximately 1 M Ω resistance, and make the same electric potential.
See "6.3 CONNECT THE PRINTER TO FRAME GROUND (FG)" for details about how to connect the Frame Ground (FG).
- Pay attention not to damage on the FPC when fixing the printer main body with the screw.

6.2 FIXING THE PLATEN UNIT

Design the platen holder at the outer case to mount the platen unit.

6.2.1 Recommended Shape of the Platen Holder

- Figure 6-2 shows a recommended shape of the platen holder.

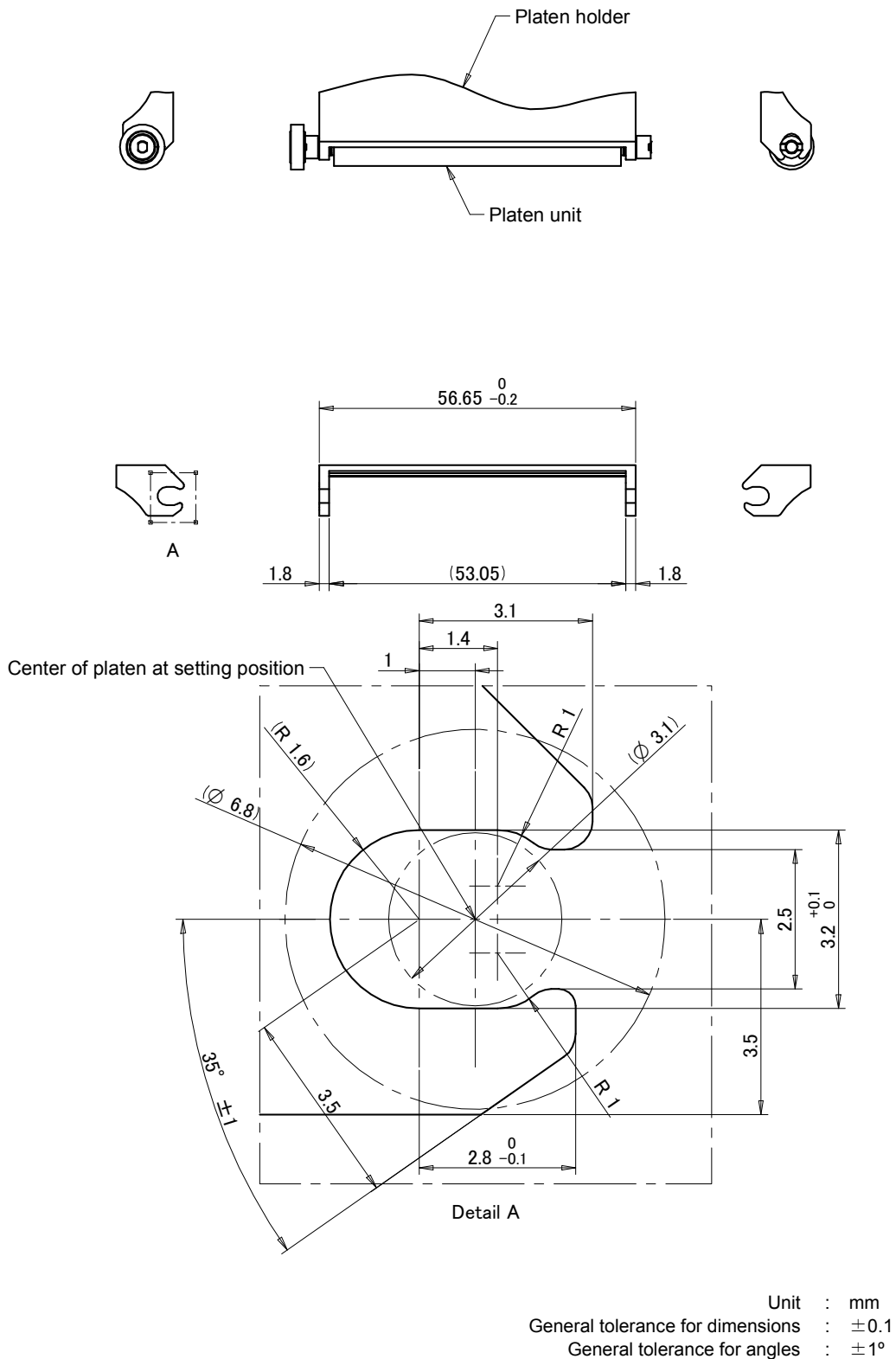
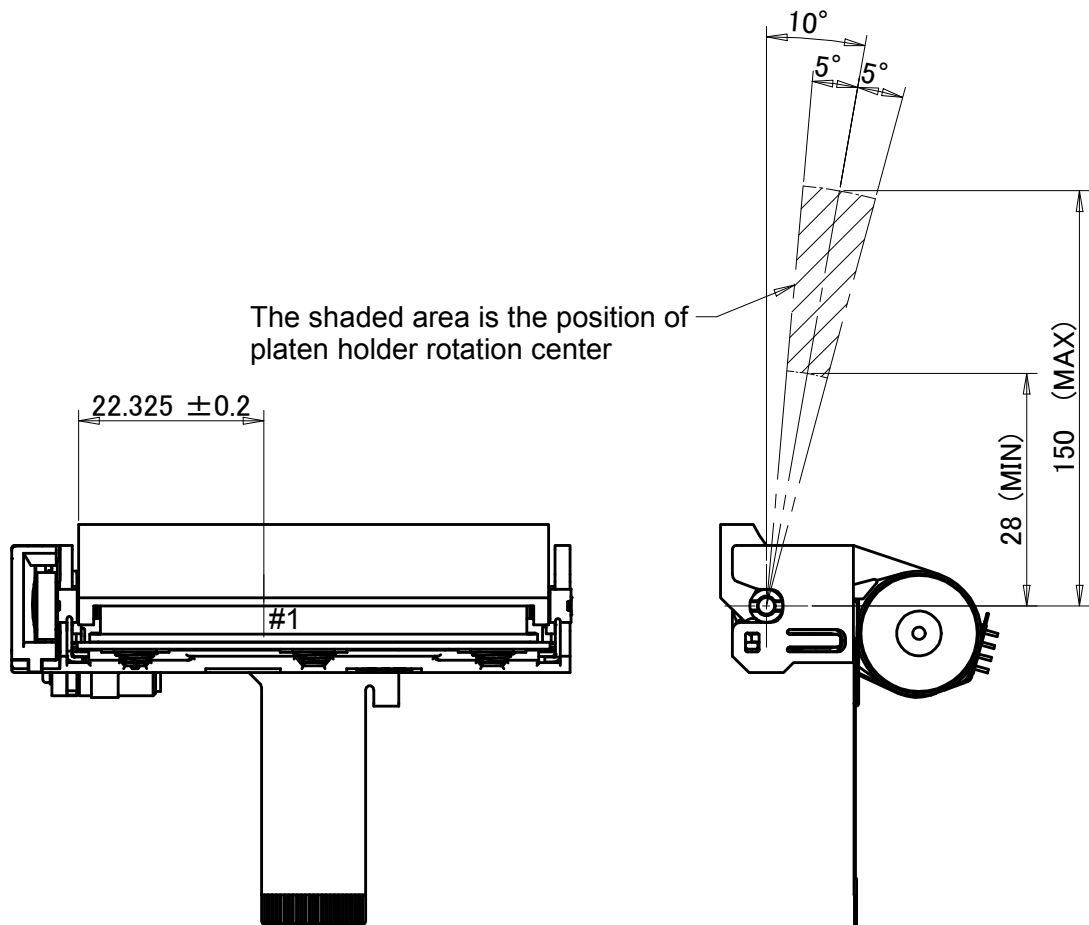

Figure 6-2 Dimensions for Positioning and Fixing the Platen Unit

6.2.2 Dimensions for Positioning and Fixing the Platen Holder

Figure 6-3 shows the rotation center area of the platen holder which is critical for setting or releasing the platen unit.



Unit : mm
General tolerance for dimensions : ± 0.1
General tolerance for angles : $\pm 1^\circ$

Figure 6-3 Dimensions for Positioning and Fixing the Platen Holder

6.2.3 Precautions for Fixing the Platen Holder

- Design the platen holder to avoid contacting with the thermal head.
- If you set the mounting part of the printer and rotation center part of the platen holder to the same base, accuracy for setting or releasing the platen unit will improve.
- It is recommended that the platen unit on which the printer main body is mounted is designed so that the platen holder is guided by part of the outer case when the platen unit is set into the printer main body.
- Design the rotation center of the rotation system of the door for the platen holder as shown in Figure 6-3. That is, based on the center line which is 10° downward from the horizontal line (which is horizontal to the printer mounting area), tolerance $\pm 5^\circ$ from that center line, and 28 mm to 150 mm away from the center of the platen. The shaded area in the Figure 6-3 is the range of rotation center of the platen holder.
- Parallelism between the positioning holes #1-#2 and the rotation center axis of platen holder should be 0.2 or less.
- Design the platen holder to be strong enough to stand against stress applied during releasing and setting the platen unit.
- Prevent from excessive stress, deformation, and torsion when fixing the platen unit.
- When the platen holder, rotation fulcrum of the platen holder, and mounting position of the platen unit are not proper, engagement of the printer main body and platen unit may be failed, resulting in printing problems.
- Do not use metal material for the platen holder. If using this, the platen unit cannot be mounted.
- Design the outer case that holds the platen holder so that the center of the platen unit will be pushed when setting or releasing the platen unit. When the edge of the platen unit is pushed, a one-sided lock phenomenon happens, and print defect and/or a paper jam may occur. It is helpful to indicate which location has to be pushed by showing a symbol on the outer case. Verify the performance with your actual device.
- Do not apply external force continuously toward the direction the platen unit is released. Otherwise, it may cause paper feed defect and printing troubles during operation.

6.3 CONNECT THE PRINTER TO FRAME GROUND (FG)

To prevent the thermal head from being damaged by static electricity, it is recommended that the printer mechanism is connected to frame ground (FG).

6.3.1 How to Connect the Printer to Frame Ground (FG)

- Contact the connecting parts to the area indicated by the arrows as shown in Figure 6-4.
- Design the connecting parts with tension like coil spring or plate spring to reduce the contact resistance.
- The connecting force must be for arrow direction as shown in Figure 6-4, vertical to the side surface of the printer main body.
- The material of the connecting parts should have superior electrical conductivity like beryllium copper.
- The connecting force should be 1N or lower.
- All Frame Ground (FG) must be same electrical potentials.
- Connect the signal ground (GND) to the frame ground (FG) using a $1M\Omega$ resistor so that the electric potential of the signal ground (GND) of the thermal head and that of the frame ground (FG) of the printer are equal.

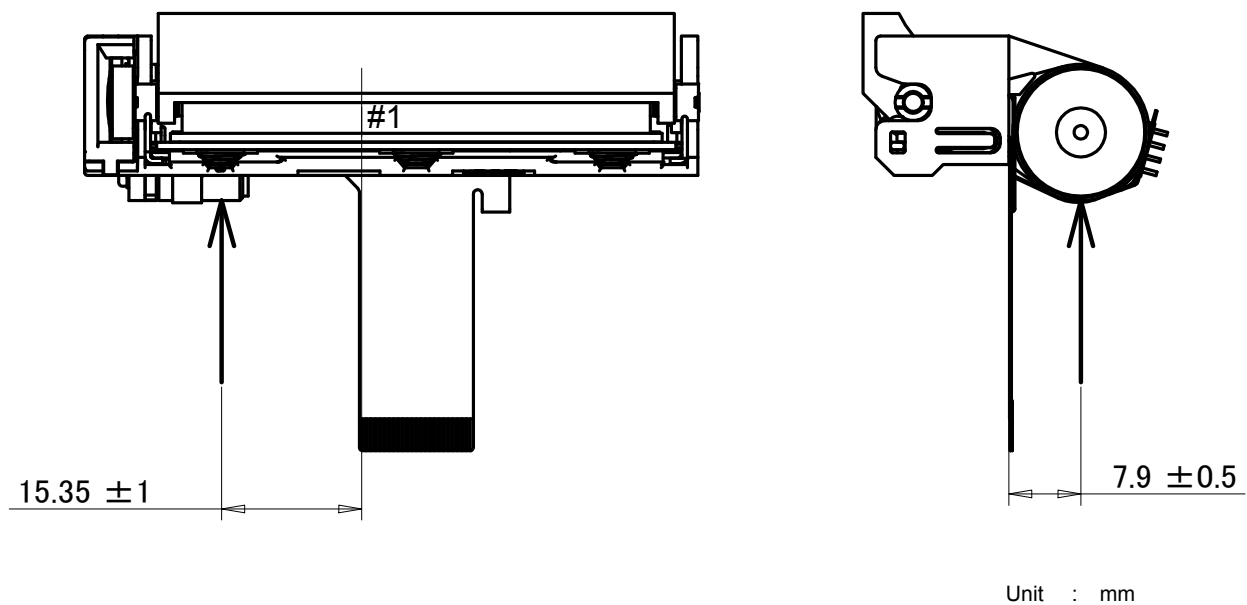

Figure 6-4 Frame Ground (FG) Connecting Area

6.4 LAYOUT OF THE PRINTER MECHANISM AND THERMAL PAPER

The printer mechanism can be laid out as shown below.

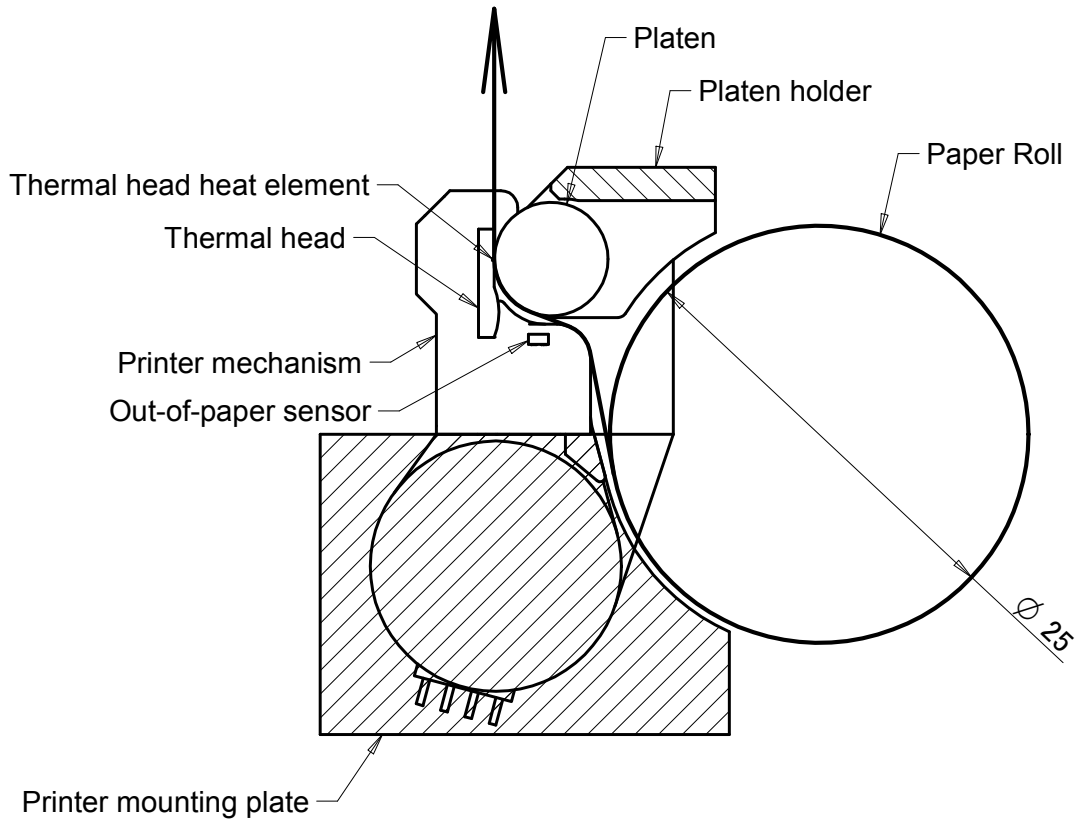

Figure 6-5 Recommended Layout between the Printer and the Paper

* The thermal paper feeding distance between the out-of-paper sensor and the heat element is approximately 5.0mm

6.5 WHERE TO MOUNT THE PAPER HOLDER

When designing the layout of the paper holder, note the followings. The recommended configuration of the paper holder is shown in Figure 6-6.

- Design the paper holder and the paper guide so that the thermal paper will be straight to the paper inlet port without any horizontal shifting and so that the center axis of the paper roll will be parallel to the printer when using paper roll.
- Design the paper holder so that the paper feed load should be 0.49N (50gf) or less. Be aware that the printing problem and paper feed problem may occur in the following case even if it is below 0.49N. Design the paper holder so as not to make these conditions and verify the performance with your actual device.

ex)

In case that the paper roll wobbles in the paper holder.

In case that tension of the thermal paper between the paper roll and the printer changes rapidly.

In addition, do not use following types of thermal paper:

Expanded paper roll

Deformed paper roll

Roll core is sticking out.

Width of the paper roll is out of spec

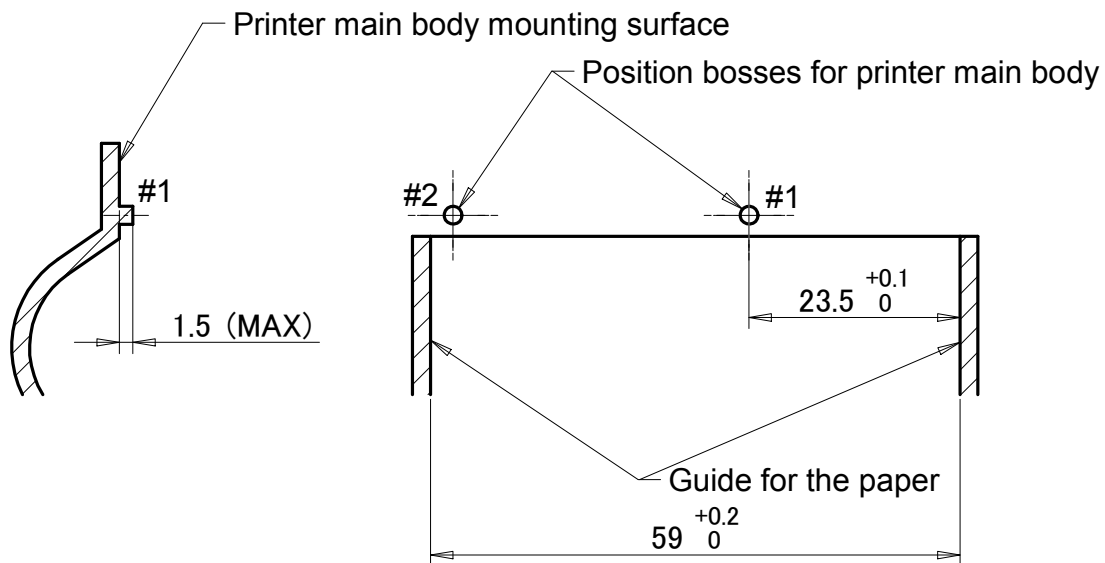

Unit : mm

Figure 6-6 Recommended Paper Holder Dimensions

6.6 DESIGN PAPER EJECT

6.6.1 Design the Shape of the Paper Eject

When designing the shape of the paper eject, note the followings.

- Design the shape of the paper eject so that stress is not applied to the thermal paper that comes out.
- Design the paper eject of the outer case and the door so that the paper eject angle must be within of 70° to 90° as shown in Figure 6-7. However, design the paper eject of outer case so that the thermal paper can be ejected without changing its eject direction. Do not change the paper eject direction around the paper eject of printer mechanism. If changing the paper eject direction, verify the performance with your actual device.

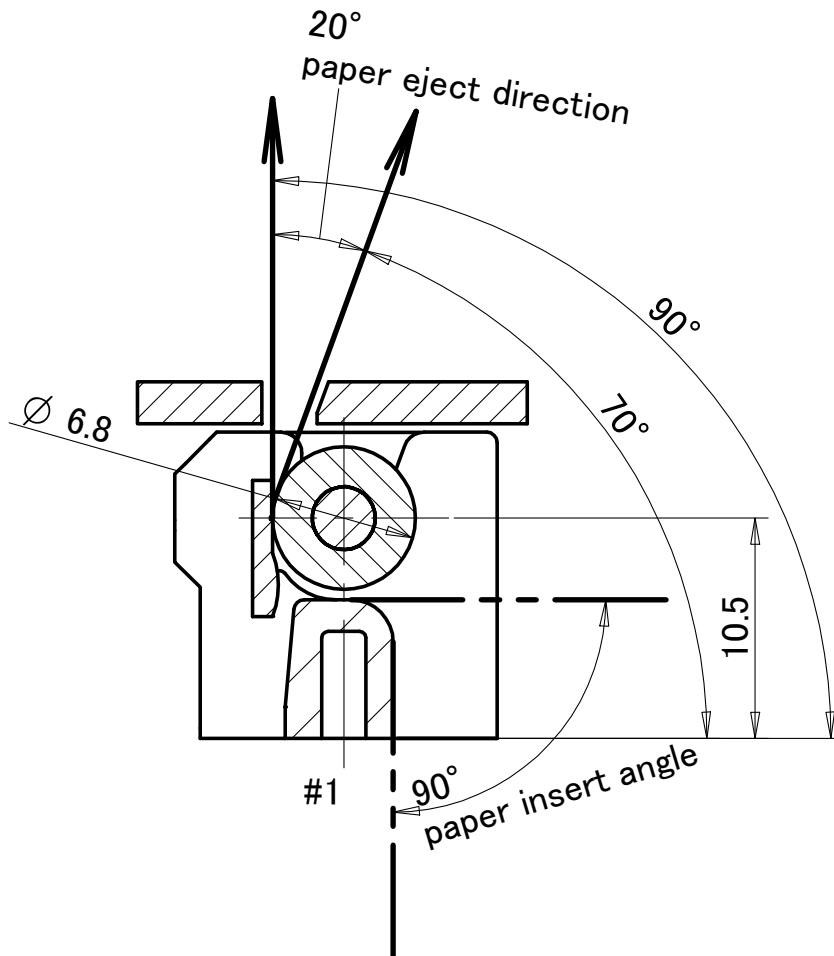

Unit : mm
General tolerance for dimensions : ± 0.1

Figure 6-7 Paper Path

6.6.2 Mount the Paper Cutter

- Design paper cutter mounting position so the edge of the cutter blade does not contact with a platen unit when the platen unit is set and released.
- Use a well-cut cutter so that the thermal paper can be cut with less force than paper holding force.
- Design the blade edge of the cutter as shown in the right figure of Figure 6-8 so that the blade edge can guide the thermal paper edge after cutting. If designing the blade edge as shown in the left figure, the paper edge may be caught by the blade edge and result in the thermal paper edge to be caught inside of the cutter.

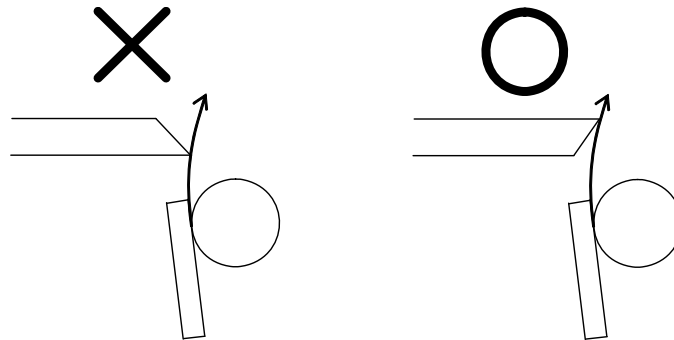

Figure 6-8 Blade Edge

6.7 PRECAUTIONS FOR DESIGNING THE OUTER CASE

- The thermal paper with a small winding diameter may cause the paper jam in the printer main body and a gap between the printer mechanism and the outer case. If using such a thermal paper with the small diameter, verify the performance with your actual device.
- Design the outer case so that it and parts for the outer case will not apply any load to the printer main body and the platen unit. The load may affect printing, and also may damage the printer mechanism. Secure 1.0mm (min.) space between the printer main body and platen unit and the outer case.
- Temperature of the thermal head and its peripherals rises very high during and immediately after printing. Be sure to design the outer case to prevent users from burn injuries by touching them. Place warning labels to warn users to ensure safe operation. As for thermal head cleaning, warn users to allow the thermal head to cool before cleaning. In order to allow cooling, secure clearance between the thermal head and the outer case when designing the outer case.
- Temperature of the motor and its peripherals rises very high during and immediately after printing. Be sure to design the outer case to prevent users from burn injuries by touching them. Place warning labels to warn users to ensure safe operation. In order to allow cooling, secure clearance between the motor and the outer case when designing the outer case.

CHAPTER 7

EXTERNAL DIMENSIONS

Figure 7-1 shows external dimensions of the platen unit. Figure 7-2 shows external dimensions of the printer.

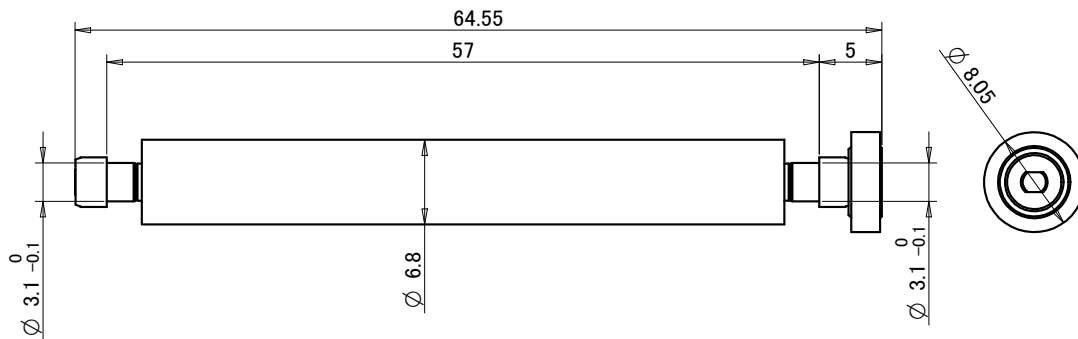

Unit : mm
General tolerance for dimensions : ± 0.5

Figure 7-1 External Dimensions of the Platen Unit

CHAPTER 8

HANDLING METHOD

8.1 PRECAUTIONS FOR INSTALLING/UNINSTALLING THE THERMAL PAPER

- Install the thermal paper with the platen unit released. Auto-loading is not allowed.
- Set the thermal paper straight to the printer and load the thermal paper until its edge is ejected for 5 cm and more from the top surface of the printer mechanism as shown in the Figure 8-1.
- When setting the platen unit, the reduction gear may interfere with the platen gear and may cause the platen unit to not be set. In such a case, release the platen unit, and set it again.
- If the thermal paper is skewed, feed the thermal paper until the thermal paper becomes straight or install the thermal paper again.
- Remove the paper jam with the platen unit released. Do not pull the thermal paper by force because severe damages may occur.

8.2 PRECAUTIONS FOR CLEANING THE THERMAL HEAD

- Do not clean the thermal head immediately after printing because the temperature of the thermal head and its peripherals rises very high during and immediately after printing.
- Clean the thermal head with the platen unit released.
- Clean the heat element shown in Figure 8-1 using a cotton swab soaked in ethyl or isopropyl alcohol.
- Do not use sandpaper, a cutter knife, or anything which may damage the heat element for cleaning.
- Set the platen unit after the alcohol has dried completely.

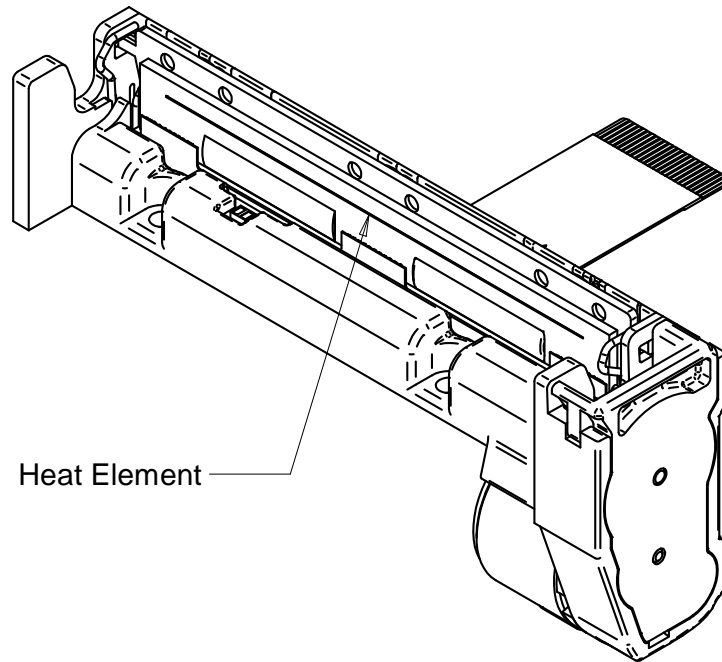

Figure 8-1 Cleaning Position of the Thermal Head