

# TECHNICAL SPECIFICATION



Model Number : QYEG0420BNS19AF0

Description : Screen Size : 4.2"  
Color : Black and White  
Display Resolution : 400\*300

**DALIAN QIYUN DISPLAY CO., LTD.**



**Specification for 4.2 inch EPD**

**Model NO. : QYEG0420BNS19AF0**

**QY's Confirmation:**

<b>Prepared by</b>	<b>Checked by</b>	<b>Approved by</b>

**Customer approval:**

<b>Customer</b>	<b>Approved by</b>	<b>Date</b>

**Revision History**

<b>Version</b>	<b>Content</b>	<b>Date</b>	<b>Producer</b>
1.0	New release	2020/4/13	
1.1	Update Storage condition for Temperature and Humidity	2020/5/9	



## CONTENTS

1.Over View.....	6
2. Features.....	6
3. Mechanical Specification.....	6
4.Mechanical Drawing of EPD Module.....	7
5. Input/output Pin Assignment.....	8
6. Electrical Characteristics.....	9
6.1 Absolute Maximum Rating.....	9
6.2 Panel DC Characteristics.....	10
6.3 Panel DC Characteristics(Driver IC Internal Regulators).....	11
6.4 Panel AC Characteristics.....	11
6.4.1 MCU Interface Selection.....	11
6.4.2 MCU Serial Interface (4-wire SPI).....	11
6.4.3 MCU Serial Interface (3-wire SPI).....	13
6.4.4 Interface Timing.....	14
7.Command Table.....	16
8. Optical Specification.....	21
9. Handling, Safety, and Environment Requirements.....	21
10. Reliability Test.....	22
11 Block Diagram .....	23



12 Typical Application Circuit with SPI Interface.....	24
13 Typical Operating Sequence.....	25
13.1 LUT from OTP Operation Flow.....	25
13.2 LUT from OTP Operation Reference Program Code.....	26
14 Part Number Definition .....	27
15 Inspection condition.....	27
15.1 Environment.....	27
15.2 Illuminance .....	27
15.3 Inspect method.....	27
15.4 Display area .....	28
15.5 Inspection standard.....	28
15.5.1 Electric inspection standard.....	28
15.5.2 Appearance inspection standard.....	29
16 Packaging.....	32



## 1. Over View

QYEG0420BNS19AF0 is an Active Matrix Electrophoretic Display (AM EPD), with interface and a reference system design. The display is capable to display images at 1-bit white, black full display capabilities. The 4.2inch active area contains 300×400 pixels. The module is a TFT-array driving electrophoresis display, with integrated circuits including gate driver, source driver, MCU interface, timing controller, oscillator, DC-DC, SRAM, LUT, VCOM. Module can be used in portable electronic devices, such as Electronic Shelf Label (ESL) System.

## 2. Features

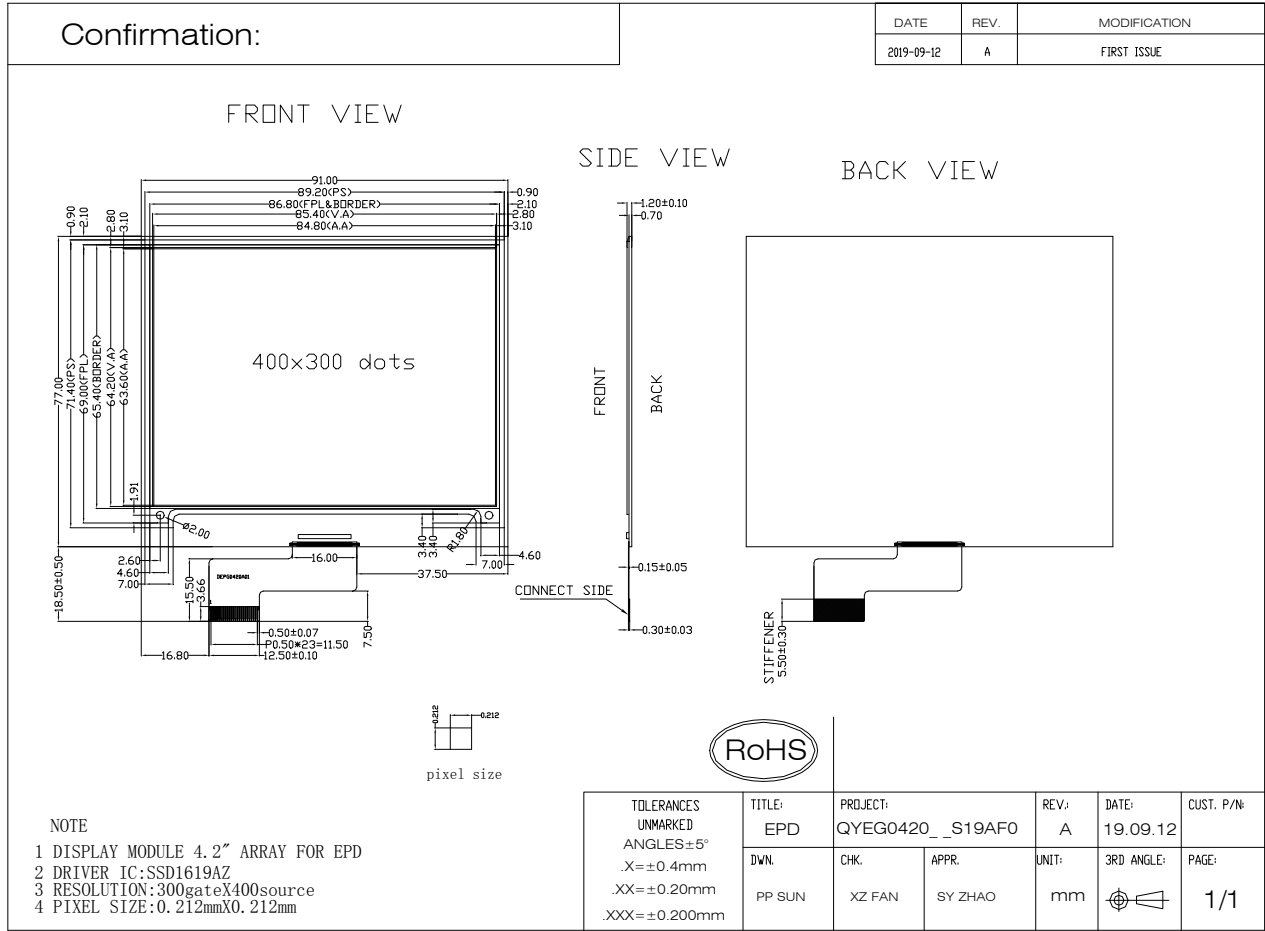
- ◆ 300×400 pixels display
- ◆ High contrast High reflectance
- ◆ Ultra wide viewing angle Ultra low power consumption
- ◆ Pure reflective mode
- ◆ Bi-stable display
- ◆ Commercial temperature range
- ◆ Landscape portrait modes
- ◆ Hard-coat antiglare display surface
- ◆ Ultra Low current deep sleep mode
- ◆ On chip display RAM
- ◆ Waveform can stored in On-chip OTP or written by MCU
- ◆ Serial peripheral interface available
- ◆ On-chip oscillator
- ◆ On-chip booster and regulator control for generating VCOM, Gate and Source driving voltage
- ◆ I<sup>2</sup>C signal master interface to read external temperature sensor
- ◆ Support partial update mode
- ◆ Built-in temperature sensor

## 3. Mechanical Specification

Parameter	Specifications	Unit	Remark
Screen Size	4.2	Inch	
Display Resolution	400(H)×300(V)	Pixel	DPI:120
Active Area	84.8×63.6	mm	
Pixel Pitch	0.212×0.212	mm	
Pixel Configuration	Rectangle		
Outline Dimension	91 (H)×77 (V) ×1.2(D)	mm	
Weight	16.1±0.3	g	



### 4.Mechanical Drawing of EPD Module





## 5. Input/output Pin Assignment

No.	Name	I/O	Description	Remark
1	NC		Do not connect with other NC pins	Keep Open
2	GDR	O	N-Channel MOSFET Gate Drive Control	
3	RESE	I	Current Sense Input for the Control Loop	
4	NC	NC	Do not connect with other NC pins	Keep Open
5	VSH2	C	Positive Source driving voltage	
6	TSCL	O	I2C Interface to digital temperature sensor Clock pin	
7	TSDA	I/O	I2C Interface to digital temperature sensor Data pin	
8	BS1	I	Bus Interface selection pin	Note 5-5
9	BUSY	O	Busy state output pin	Note 5-4
10	RES#	I	Reset signal input. Active Low.	Note 5-3
11	D/C#	I	Data /Command control pin	Note 5-2
12	CS#	I	Chip select input pin	Note 5-1
13	SCL	I	Serial Clock pin (SPI)	
14	SDA	I/O	Serial Data pin (SPI)	
15	VDDIO	P	Power Supply for interface logic pins It should be connected with VCI	
16	VCI	P	Power Supply for the chip	
17	VSS	P	Ground	
18	VDD	C	Core logic power pin VDD can be regulated internally from VCI. A capacitor should be connected between VDD and VSS	
19	VPP	P	FOR TEST	Keep Open
20	VSH1	C	Positive Source driving voltage	
21	VGH	C	Power Supply pin for Positive Gate driving voltage and VSH1	
22	VSL	C	Negative Source driving voltage	
23	VGL	C	Power Supply pin for Negative Gate driving voltage VCOM and VSL	
24	VCOM	C	VCOM driving voltage	





I = Input Pin, O =Output Pin, I/O = Bi-directional Pin (Input/output), P = Power Pin, C = Capacitor Pin

Note 5-1: This pin (CS#) is the chip select input connecting to the MCU. The chip is enabled for MCU communication only when CS# is pulled LOW.

Note 5-2: This pin is (D/C#) Data/Command control pin connecting to the MCU in 4-wire SPI mode. When the pin is pulled HIGH, the data at SDA will be interpreted as data. When the pin is pulled LOW, the data at SDA will be interpreted as command.

Note 5-3: This pin (RES#) is reset signal input. The Reset is active low.

Note 5-4: This pin is Busy state output pin. When Busy is High, the operation of chip should not be interrupted, command should not be sent. The chip would put Busy pin High when -Outputting display waveform -Communicating with digital temperature sensor

Note 5-5: Bus interface selection pin

BS1 State	MCU Interface
L	4-lines serial peripheral interface(SPI) - 8 bits SPI
H	3- lines serial peripheral interface(SPI) - 9 bits SPI

## 6. Electrical Characteristics

### 6.1 Absolute Maximum Rating

Parameter	Symbol	Rating	Unit
Logic supply voltage	VCI	-0.5 to +4.0	V
Logic Input voltage	VIN	-0.5 to VCI +0.5	V
Logic Output voltage	VOU	-0.5 to VCI +0.5	V
Operating Temp range	TOPR	0 to +50	°C.
Storage Temp range	TSTG	-25 to +70	°C.
Optimal Storage Temp	TSTGo	23±3	°C.
Optimal Storage Humidity	HSTGo	55±10	%RH

Note: Maximum ratings are those values beyond which damages to the device may occur. Functional operation should be restricted to the limits in the Panel DC Characteristics tables.

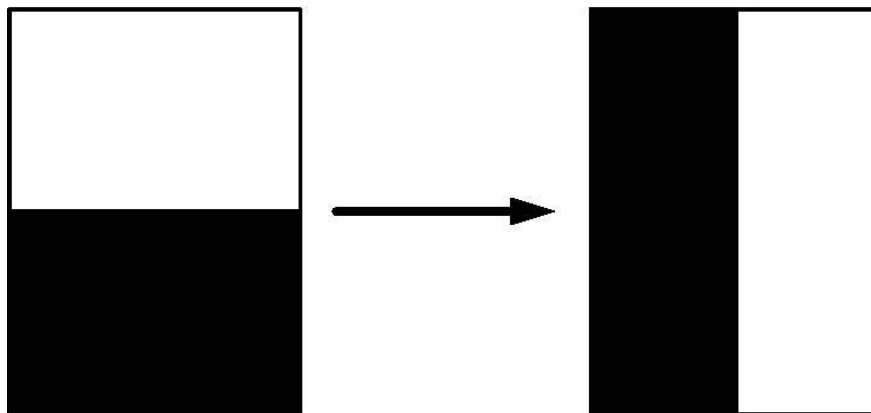


## 6.2 Panel DC Characteristics

The following specifications apply for: VSS=0V, VCI=3.0V, TOPR =25°C.

Parameter	Symbol	Condition	Applicable pin	Min.	Typ.	Max.	Unit
Single ground	VSS	-		-	0	-	V
Logic supply voltage	VCI	-	VCI	2.2	3.0	3.7	V
Core logic voltage	VDD		VDD	1.7	1.8	1.9	V
High level input voltage	V <sub>IH</sub>	-	-	0.8 V <sub>CI</sub>	-	-	V
Low level input voltage	V <sub>IL</sub>	-	-	-	-	0.2 V <sub>CI</sub>	V
High level output voltage	V <sub>OH</sub>	IOH = -100uA	-	0.9 V <sub>CI</sub>	-	-	V
Low level output voltage	V <sub>OL</sub>	IOL = 100uA	-	-	-	0.1 V <sub>CI</sub>	V
Typical power	P <sub>TYP</sub>	V <sub>CI</sub> =3.0V	-	-	12.6	-	mW
Deep sleep mode	P <sub>STPY</sub>	V <sub>CI</sub> =3.0V	-	-	0.003	-	mW
Typical operating current	Iopr_VCI	V <sub>CI</sub> =3.0V	-	-	4.2	-	mA
Image update time	-	25 °C	-	-	5	-	sec
Sleep mode current	Islp_VCI	DC/DC off No clock No input load Ram data retain	-	-	20	-	uA
Deep sleep mode current	Idslp_VCI	DC/DC off No clock No input load Ram data not retain	-	-	1	-	uA

Notes: 1. The typical power is measured with following transition from horizontal 2 scale pattern to vertical 2 scale pattern.



2. The deep sleep power is the consumed power when the panel controller is in deep sleep mode.
3. The listed electrical/optical characteristics are only guaranteed under the controller & waveform provided by QY.



### 6.3 Panel DC Characteristics(Driver IC Internal Regulators)

The following specifications apply for: VSS=0V, VCI=3.0V, TOPR =25°C.

Parameter	Symbol	Condition	Applicable pin	Min.	Typ.	Max.	Unit
VCOM output voltage	VCOM	-	VCOM	-	TBD	-	V
Positive Source output voltage	V <sub>SH</sub>	-	S <sub>0</sub> ~S <sub>399</sub>	+14.5	+15	+15.5	V
Negative Source output voltage	V <sub>SL</sub>	-	S <sub>0</sub> ~S <sub>399</sub>	-15.5	-15	-14.5	V
Positive gate output voltage	V <sub>gh</sub>	-	G <sub>0</sub> ~G <sub>299</sub>	+21	+22	+23	V
Negative gate output voltage	V <sub>gl</sub>	-	G <sub>0</sub> ~G <sub>299</sub>	-21	-20	-19	V

### 6.4 Panel AC Characteristics

#### 6.4.1 MCU Interface Selection

The pin assignment at different interface mode is summarized in Table 6-4-1. Different MCU mode can be set by hardware selection on BS1 pins. The display panel only supports 4-wire SPI or 3-wire SPI interface mode.

Pin Name	Data/Command Interface		Control Signal		
	SDA	SCL	CS#	D/C#	RES#
Bus interface	SDA	SCL	CS#	D/C#	RES#
BS1=L 4-wire SPI	SDA	SCL	CS#	D/C#	RES#
BS1=H 3-wire SPI	SDA	SCL	CS#	L	RES#

#### 6.4.2 MCU Serial Interface (4-wire SPI)

The serial interface consists of serial clock SCL, serial data SDA, D/C#, CS#. This interface supports Write mode and Read mode.

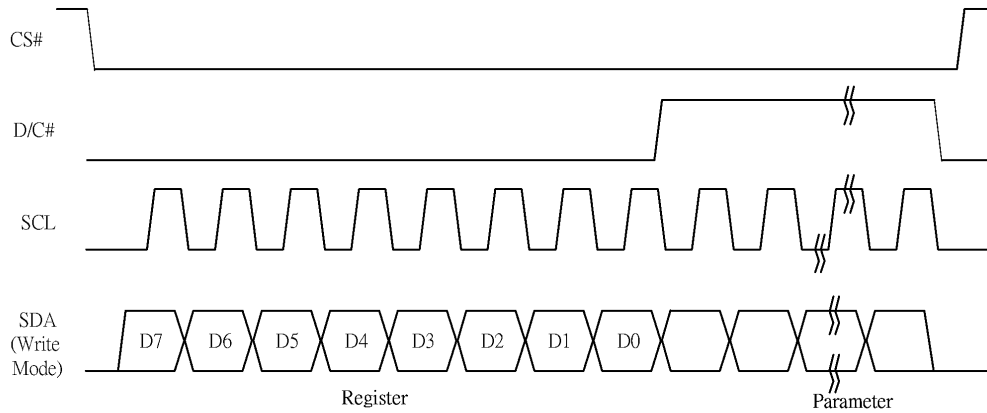
Function	CS#	D/C#	SCL
Write command	L	L	↑
Write data	L	H	↑

Note: ↑ stands for rising edge of signal

In the write mode SDA is shifted into an 8-bit shift register on every rising edge of SCL in the order of D7, D6, ... D0. The level of D/C# should be kept over the whole byte. The data byte in the shift register is written to the Graphic Display Data RAM /Data Byte register or command Byte register according to D/C# pin.



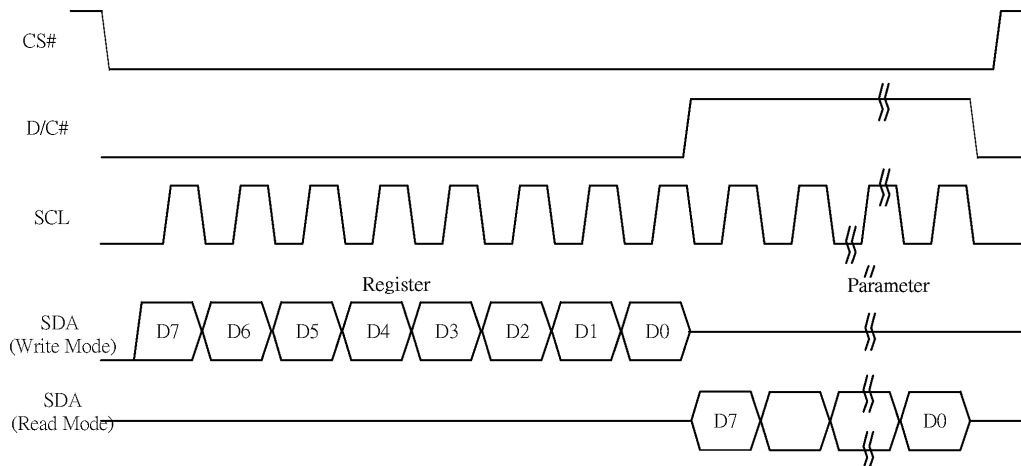
Figure 6-1: Write procedure in 4-wire SPI mode



In the Read mode:

1. After driving CS# to low, MCU need to define the register to be read.
2. SDA is shifted into an 8-bit shift register on every rising edge of SCL in the order of D7, D6, ... D0 with D/C# keep low.
3. After SCL change to low for the last bit of register, D/C# need to drive to high.
4. SDA is shifted out an 8-bit data on every falling edge of SCL in the order of D7, D6, ... D0.
5. Depending on register type, more than 1 byte can be read out. After all byte are read, CS# need to drive to high to stop the read operation.

Figure 6-2: Read procedure in 4-wire SPI mode





### 6.4.3 MCU Serial Interface (3-wire SPI)

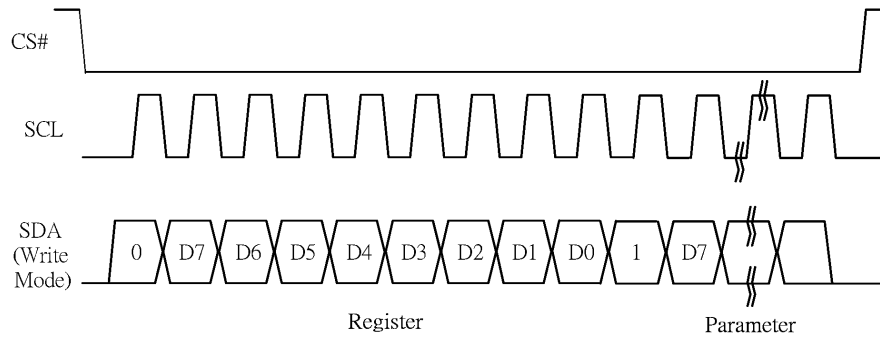
The 3-wire serial interface consists of serial clock SCL, serial data SDA and CS#. This interface also supports Write mode and Read mode.

The operation is similar to 4-wire serial interface while D/C# pin is not used. There are altogether 9-bits will be shifted into the shift register on every ninth clock in sequence: D/C# bit, D7 to D0 bit. The D/C# bit (first bit of the sequential data) will determine the following data byte in the shift register is written to the Display Data RAM (D/C# bit = 1) or the command register (D/C# bit = 0).

Function	CS#	D/C#	SCL
Write command	L	Tie	↑
Write data	L	Tie	↑

Note: ↑ stands for rising edge of signal

Figure 6-3: Write procedure in 3-wire SPI mode

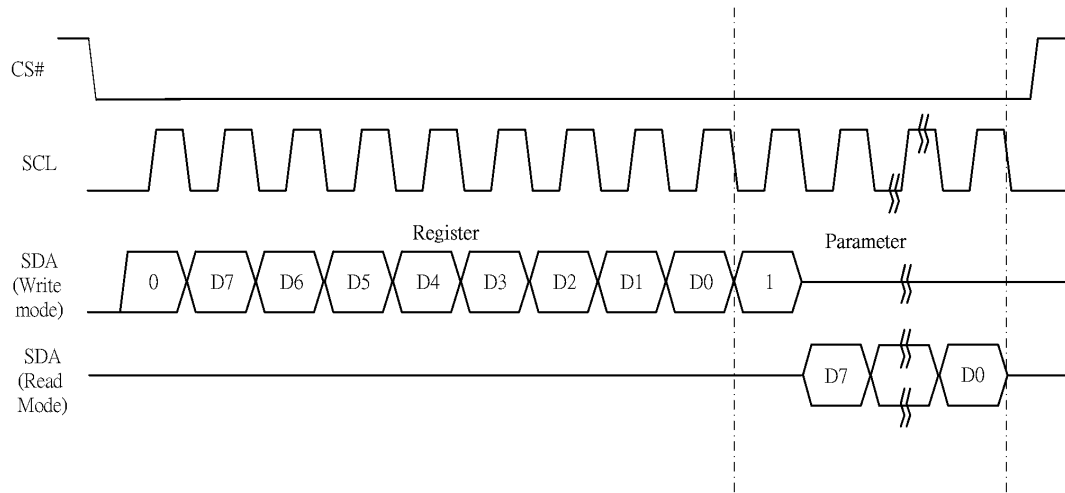


In the Read mode:

1. After driving CS# to low, MCU need to define the register to be read.
2. D/C=0 is shifted thru SDA with one rising edge of SCL
3. SDA is shifted into an 8-bit shift register on every rising edge of SCL in the order of D7, D6, ... D0.
4. D/C=1 is shifted thru SDA with one rising edge of SCL
5. SDA is shifted out an 8-bit data on every falling edge of SCL in the order of D7, D6, ... D0.
6. Depending on register type, more than 1 byte can be read out. After all byte are read, CS# need to drive to high to stop the read operation.

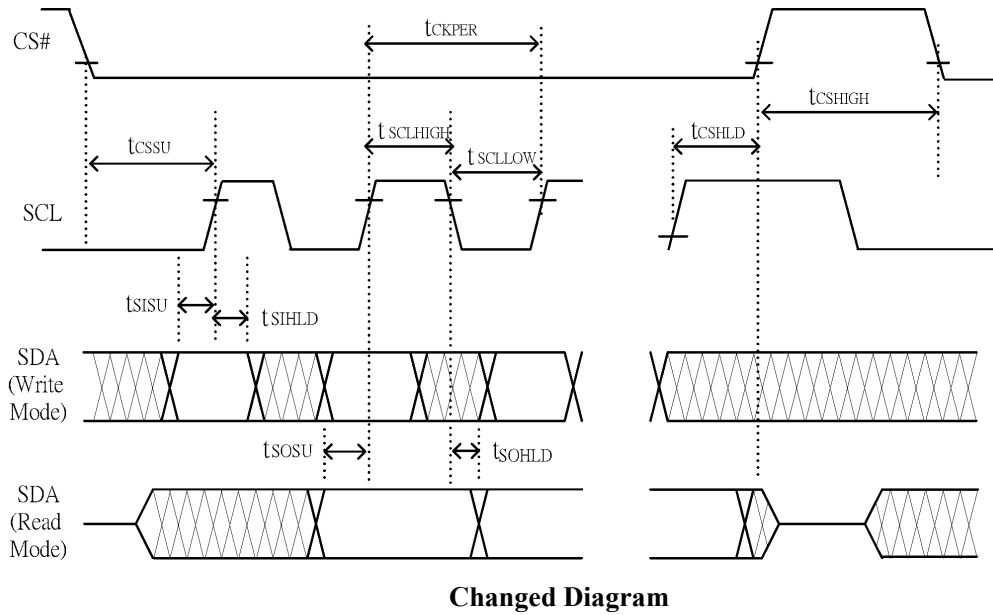


Figure 6-4: Read procedure in 3-wire SPI mode



### 6.4.4 Interface Timing

The following specifications apply for: VSS=0V, VCI=3.0V, TOPR =25°C.



**Serial Interface Timing Characteristics**

(VCI - VSS = 2.2V to 3.7V, TOPR = 25°C, CL=20pF)

**Write mode**

Symbol	Parameter	Min	Typ	Max	Unit
fSCL	SCL frequency (Write Mode)			20	MHz
tCSSU	Time CS# has to be low before the first rising edge of SCLK	20			ns
tCSHLD	Time CS# has to remain low after the last falling edge of SCLK	20			ns
tCSHIGH	Time CS# has to remain high between two transfers	100			ns
tSCLHIGH	Part of the clock period where SCL has to remain high	25			ns
tSCLLOW	Part of the clock period where SCL has to remain low	25			ns
tSISU	Time SI (SDA Write Mode) has to be stable before the next rising edge of SCL	10			ns
tSIHLD	Time SI (SDA Write Mode) has to remain stable after the rising edge of SCL	40			ns

**Read mode**

Symbol	Parameter	Min	Typ	Max	Unit
fSCL	SCL frequency (Read Mode)			2.5	MHz
tCSSU	Time CS# has to be low before the first rising edge of SCLK	100			ns
tCSHLD	Time CS# has to remain low after the last falling edge of SCLK	50			ns
tCSHIGH	Time CS# has to remain high between two transfers	250			ns
tSCLHIGH	Part of the clock period where SCL has to remain high	180			ns
tSCLLOW	Part of the clock period where SCL has to remain low	180			ns
tSOSU	Time SO(SDA Read Mode) will be stable before the next rising edge of SCL		50		ns
tSOHLD	Time SO (SDA Read Mode) will remain stable after the falling edge of SCL		0		ns



## 7.Command Table

R/W#	D/C#	Hex	D7	D6	D5	D4	D3	D2	D1	D0	Command	Description	
0	0	01	0	0	0	0	0	0	0	1	Driver Output control	Gate setting Set A[8:0]=012Bh Set B[8:0]=00h	
0	1		A7	A6	A5	A4	A3	A2	A1	A0			
0	1		0	0	0	0	0	0	0	A8			
0	1		0	0	0	0	0	B2	B1	B0			
0	0	03	0	0	0	0	0	0	1	1	Gate Driving voltage control	SetGate Driving voltage A[4:0]=17h[POR],VGH at 20V[POR] VGH setting from 10V to 21V	
0	1		0	0	0	A4	A3	A2	A1	A0			
0	0	04	0	0	0	0	0	1	0	0	Source Driving voltage control	SetSource Driving voltage A[7:0]= 41h[POR],VSH1 at 15V B[7:0]=A Ch[POR],VSH2 at 5.4V C[7:0]= 32h[POR], VSL at -15V	
0	1		A7	A6	A5	A4	A3	A2	A1	A0			
0	1		B7	B6	B5	B4	B3	B2	B1	B0			
0	1		C7	C6	C5	C4	C3	C2	C1	C0			
0	0	10	0	0	0	1	0	0	0	0	Deep Sleep mode	Deep Sleep mode Control	
0	1		0	0	0	0	0	0	0	A <sub>0</sub>		A[0] :	Description
												0	Normal Mode [POR]
												1	Enter Deep Sleep Mode
0	0	11	0	0	0	1	0	0	0	1	Data Entry mode setting	Define data entry sequence A [1:0] = ID[1:0]Address automatic increment / decrement setting The setting of incrementing or decrementing of the address counter can be made independently in each upper and lower bit of the address. 00 –Y decrement, X decrement, 01 –Y decrement, X increment, 10 –Y increment, X decrement, 11 –Y increment, X increment [POR] A[2] = AM Set the direction in which the address counter is updated automatically after data are written to the RAM. AM= 0, the address counter is updated in the X direction. [POR] AM = 1, the address counter is updated in the Y direction.	
0	1		0	0	0	0	0	A <sub>2</sub>	A <sub>1</sub>	A <sub>0</sub>			
0	0	12	0	0	0	1	0	0	1	0	SWRESET	It resets the commands and parameters to their S/W Reset default values except R10h-Deep Sleep Mode Note: RAM are unaffected by this command.	
0	0	18	0	0	0	1	1	0	0	0	Temperature Sensor Control	Temperature Sensor Selection A[7:0] = 48h [POR], external temperature sensor A[7:0] = 80h Internal temperature sensor	





0	0	1A	0	0	0	1	1	0	1	0	Temperature Sensor Control	Write to temperature register. A[7:0] – MSByte 01111111[POR] B[7:0] – LSByte 11110000[POR]
0	1		A7	A6	A5	A4	A3	A2	A1	A0		
0	1		B7	B6	B5	B4	0	0	0	0		
0	0	20	0	0	1	0	0	0	0	0	Master Activation	Activate Display Update Sequence The Display Update Sequence Option is located at R22h User should not interrupt this operation to avoid corruption of panel images.
0	0	21	0	0	1	0	0	0	0	1	Display Update Control 1	RAM content option for Display Update BW RAM option A[7:4]=0100 (For BW)  A[3:0]=0000[POR] Normal  A[3:0]=0100 Bypass RAM content as 0  A[3:0]=0100 Inverse RAM content
0	1		0	0	0	0	A3	A2	A1	A0		
0	0	22	0	0	1	0	0	0	1	0	Display Update Control 2	Display Update Sequence Option: Enable the stage for Master Activation
	1		A7	A6	A5	A4	A3	A2	A1	A0		<b>Setting for LUT from MCU</b>
												Enable Clock Signal, Then Enable Analog Then PATTERN DISPLAY C7 Then Disable Analog Then Disable OSC
												<b>Setting for LUT from OTP according to external Temperature Sensor operation</b>
												Then Enable Analog Then Load LUT
											90	
											Enable Analog Then PATTERN DISPLAY Then Disable Analog Then Disable OSC	
											47	
0	0	24	0	0	1	0	0	1	0	0	Write RAM (BW)	After this command, data entries will be written into the 1RAM until another command is written. Address pointers will advance accordingly. For Write pixel: Content of write RAM(BW)=1 For Black pixel: Content of write RAM(BW)=0



0	0	26	0	0	1	0	0	1	1	0	Write RAM (RED)	After this command, data entries will be written into the 2 RAM until another command is written. Address pointers will advance accordingly. For RED pixel: Content of write RAM(RED)=1 For White/Black pixel: Content of write RAM(RED)=0		
0	0	2C	0	0	1	0	1	1	0	0	Write VCOM register	Set A[7:0]=4Bh		
0	1		A7	A6	A5	A4	A3	A2	A1	A0				
0	0	2D	0	0	1	0	1	1	0	1	OTP Register Read	Read Register stored in OTP: 1. A[7:0]~ B[7:0]: VCOM Information 3. C[7:0]~F[7:0]: Reserved 4. G[7:0]~H[7:0]: Module ID/ Waveform Version [2bytes]		
1	1		A7	A6	A5	A4	A3	A2	A1	A0				
1	1		B7	B6	B5	B4	B3	B2	B1	B0				
1	1		C7	C6	C5	C4	C3	C2	C1	C0				
1	1		D7	D6	D5	D4	D3	D2	D1	D0				
1	1		E7	E6	E5	E4	E3	E2	E1	E0				
1	1		F7	F6	F5	F4	F3	F2	F1	F0				
1	1		G7	G6	G5	G4	G3	G2	G1	G0				
1	1		H7	H6	H5	H4	H3	H2	H1	H0				
0	0	2F	0	0	1	0	1	1	1	1			Status Bit Read	Read IC status Bit [POR 0x21] A[5]: HV Ready Detection flag [POR=1]  0: Ready 1: Not Ready A[4]: VCI Detection flag [POR=0]  0: Normal 1: VCI lower than the Detect level A[3]: [POR=0] A[2]: Busy flag [POR=0] 0: Normal 1: BUSY A[1:0]: Chip ID [POR=01] Remark: A[5] and A[4] status are not valid after RESET, they need to be initiated by command 0x14 and command 0x15 respectively.
1	1		0	0	A5	A4	0	0	A1	A0				
0	0	32	0	0	1	1	0	0	1	0	Write LUT register	Write LUT register from MCU interface [70 bytes].		
0	1		A7	A6	A5	A4	A3	A2	A1	A0				
0	1		B7	B6	B5	B4	B3	B2	B1	B0				
0	1		:	:	:	:	:	:	:	:				
0	1		:	:	:	:	:	:	:	:				
0	1		:	:	:	:	:	:	:	:				
0	1		:	:	:	:	:	:	:	:				



0	0	3A	0	0	1	1	1	0	1	0	Set dummy line period	Set A[6:0]=2Ch Default value will give 50Hz Frame frequency
0	1		0	A <sub>6</sub>	A <sub>5</sub>	A <sub>4</sub>	A <sub>3</sub>	A <sub>2</sub>	A <sub>1</sub>	A <sub>0</sub>		
0	0	3B	0	0	1	1	1	0	1	1	Set Gate line width	Set A[3:0]=0Ah Default value will give 50Hz Frame frequency
0	1		0	0	0	0	A <sub>3</sub>	A <sub>2</sub>	A <sub>1</sub>	A <sub>0</sub>		
0	0	3C	0	0	1	1	1	1	0	0	Border Waveform Control	Select border waveform for VBD A [7:6] Select VBD
0	1		A <sub>7</sub>	A <sub>6</sub>	A <sub>5</sub>	A <sub>4</sub>	0	0	A <sub>1</sub>	A <sub>0</sub>		
												A[7:6] Select VBD as
												00[POR] GS Transition Define A[1:0]
												01 Fix Level Define A [5:4]
												10 VCOM
												11 HIZ
												A [5:4] Fix Level Setting for VBD
												A[5:4] VBD level
												00[POR] VSS
												01 VSH1
												10 VSL
												11 VSH2
												A[1:0] BW Transition setting for VBD
												A[1:0] VBD Transition
												00 [POR] LUT0
												01 LUT1
												10 LUT2
												11 LUT3
0	0	44	0	1	0	0	0	1	0	0	Set RAM X - address Start / End position	Specify the start/end positions of the window address in the X direction by an address unit A[5:0]: XSA[5:0], X Start, POR = 00h B[5:0]: XEA[5:0], X End, POR = 31h
0	1		0	0	A <sub>5</sub>	A <sub>4</sub>	A <sub>3</sub>	A <sub>2</sub>	A <sub>1</sub>	A <sub>0</sub>		
0	1		0	0	B <sub>5</sub>	B <sub>4</sub>	B <sub>3</sub>	B <sub>2</sub>	B <sub>1</sub>	B <sub>0</sub>		
0	0	45	0	1	0	0	0	1	0	1	Set Ram Y- address Start / End position	Specify the start/end positions of the window address in the Y direction by an address unit A[8:0]: YSA[8:0], Y Start, POR = 012Bh B[8:0]: YEA[8:0], Y End, POR = 0000h
0	1		A <sub>7</sub>	A <sub>6</sub>	A <sub>5</sub>	A <sub>4</sub>	A <sub>3</sub>	A <sub>2</sub>	A <sub>1</sub>	A <sub>0</sub>		
0	1		0	0	0	0	0	0	0	A <sub>8</sub>		
0	1		B <sub>7</sub>	B <sub>6</sub>	B <sub>5</sub>	B <sub>4</sub>	B <sub>3</sub>	B <sub>2</sub>	B <sub>1</sub>	B <sub>0</sub>		
0	1		0	0	0	0	0	0	0	B <sub>8</sub>		
0	0	4E	0	1	0	0	1	1	1	0	Set RAM X address counter	Make initial settings for the RAM X address in the address counter (AC) A[5:0]: XAD[5:0], POR is 00h
0	1		0	0	A <sub>5</sub>	A <sub>4</sub>	A <sub>3</sub>	A <sub>2</sub>	A <sub>1</sub>	A <sub>0</sub>		
0	0	4F	0	1	0	0	1	1	1	1	Set RAM Y address counter	Make initial settings for the RAM Y address in the address counter (AC) A[8:0]: YAD8:0], POR is 012Bh
0	1		A <sub>7</sub>	A <sub>6</sub>	A <sub>5</sub>	A <sub>4</sub>	A <sub>3</sub>	A <sub>2</sub>	A <sub>1</sub>	A <sub>0</sub>		
0	1		0	0	0	0	0	0	0	A <sub>8</sub>		
0	0	74	0	1	1	1	0	1	0	0	Set Analog Block control	A[7:0] = 54h
0	1		A <sub>7</sub>	A <sub>6</sub>	A <sub>5</sub>	A <sub>4</sub>	A <sub>3</sub>	A <sub>2</sub>	A <sub>1</sub>	A <sub>0</sub>		
0	0	7E	0	1	1	1	1	1	1	0	Set Digital Block control	A[7:0] = 3Bh
0	1		A <sub>7</sub>	A <sub>6</sub>	A <sub>5</sub>	A <sub>4</sub>	A <sub>3</sub>	A <sub>2</sub>	A <sub>1</sub>	A <sub>0</sub>		



0	0	0C	0	0	0	0	1	1	0	0	Booster Soft start Control	Booster Enable with Phase 1, Phase 2 and Phase 3 for soft start current and duration setting. A[7:0] -> Soft start setting for Phase1 = 8Bh [POR] B[7:0] -> Soft start setting for Phase2 = 9Ch [POR] C[7:0] -> Soft start setting for Phase3 = 96h [POR] D[7:0] -> Duration setting = 0Fh [POR] Bit Description of each byte: A[6:0] / B[6:0] / C[6:0]:
0	1		1	A <sub>6</sub>	A <sub>5</sub>	A <sub>4</sub>	A <sub>3</sub>	A <sub>2</sub>	A <sub>1</sub>	A <sub>0</sub>		
0	1		1	B <sub>6</sub>	B <sub>5</sub>	B <sub>4</sub>	B <sub>3</sub>	B <sub>2</sub>	B <sub>1</sub>	B <sub>0</sub>		
0	1		1	C <sub>6</sub>	C <sub>5</sub>	C <sub>4</sub>	C <sub>3</sub>	C <sub>2</sub>	C <sub>1</sub>	C <sub>0</sub>		
0	1		0	0	D <sub>5</sub>	D <sub>4</sub>	D <sub>3</sub>	D <sub>2</sub>	D <sub>1</sub>	D <sub>0</sub>		
0	0	2B	0	0	1	0	1	0	1	1	Write Register for VCOM Control	This command is used to reduce glitch when ACVCOM toggle. Two data bytes D04h and D63h should be set for this Command.
0	1		0	0	0	0	0	1	0	0		
0	1		0	1	1	0	0	0	1	1		

Bit[6:4]	Driving Selection Strength
000	1(Weakest)
001	2
010	3
011	4
100	5
101	6
110	7
111	8(Strongest)

Bit[3:0]	Min Off Time Setting of GDR [ Time unit ]
0000 ~ 0011	NA
0100	2.6
0101	3.2
0110	3.9
0111	4.6
1000	5.4
1001	6.3
1010	7.3
1011	8.4
1100	9.8
1101	11.5
1110	13.8
1111	16.5

D[5:0]: duration setting of phase  
 D[5:4]: duration setting of phase 3  
 D[3:2]: duration setting of phase 2  
 D[1:0]: duration setting of phase 1

Bit[1:0]	Duration of Phase [Approximation]
00	10ms
01	20ms
10	30ms
11	40ms



## 8. Optical Specification

Measurements are made with that the illumination is under an angle of 45 degree, the detection is perpendicular unless otherwise specified

Symbol	Parameter	Conditions	Min	Typ.	Max	Units	Notes
R	White Reflectivity	White	30	35	-	%	8-1
CR	Contrast Ratio	indoor	8:1		-		8-2
GN	2Grey Level	-	-	-	-		
T update	Image update time	at 25 °C	-	3	-	sec	
Life		Temp:23±3°C Humidity:55±10%RH		5years			8-3

**Notes: 8-1. Luminance meter: Eye-One Pro Spectrophotometer.**

**8-2. CR=Surface Reflectance with all white pixel/Surface Reflectance with all black pixels.**

**8-3. When the product is stored. The display screen should be kept white and face up.**

## 9. Handling, Safety, and Environment Requirements

### Warning

The display glass may break when it is dropped or bumped on a hard surface. Handle with care. Should the display break, do not touch the electrophoretic material. In case of contact with electrophoretic material, wash with water and soap.

### Caution

The display module should not be exposed to harmful gases, such as acid and alkali gases, which corrode electronic components. Disassembling the display module.

Disassembling the display module can cause permanent damage and invalidates the warranty agreements.

Observe general precautions that are common to handling delicate electronic components. The glass can break and front surfaces can easily be damaged. Moreover the display is sensitive to static electricity and other rough environmental conditions.

Data sheet status	
Product specification	This data sheet contains final product specifications.
Limiting values	
Limiting values given are in accordance with the Absolute Maximum Rating System (IEC 134). Stress above one or more of the limiting values may cause permanent damage to the device. These are stress ratings only and operation of the device at these or at any other conditions above those given in the Characteristics sections of the specification is not implied. Exposure to limiting values for extended periods may affect device reliability.	
Application information	
Where application information is given, it is advisory and does not form part of the specification.	



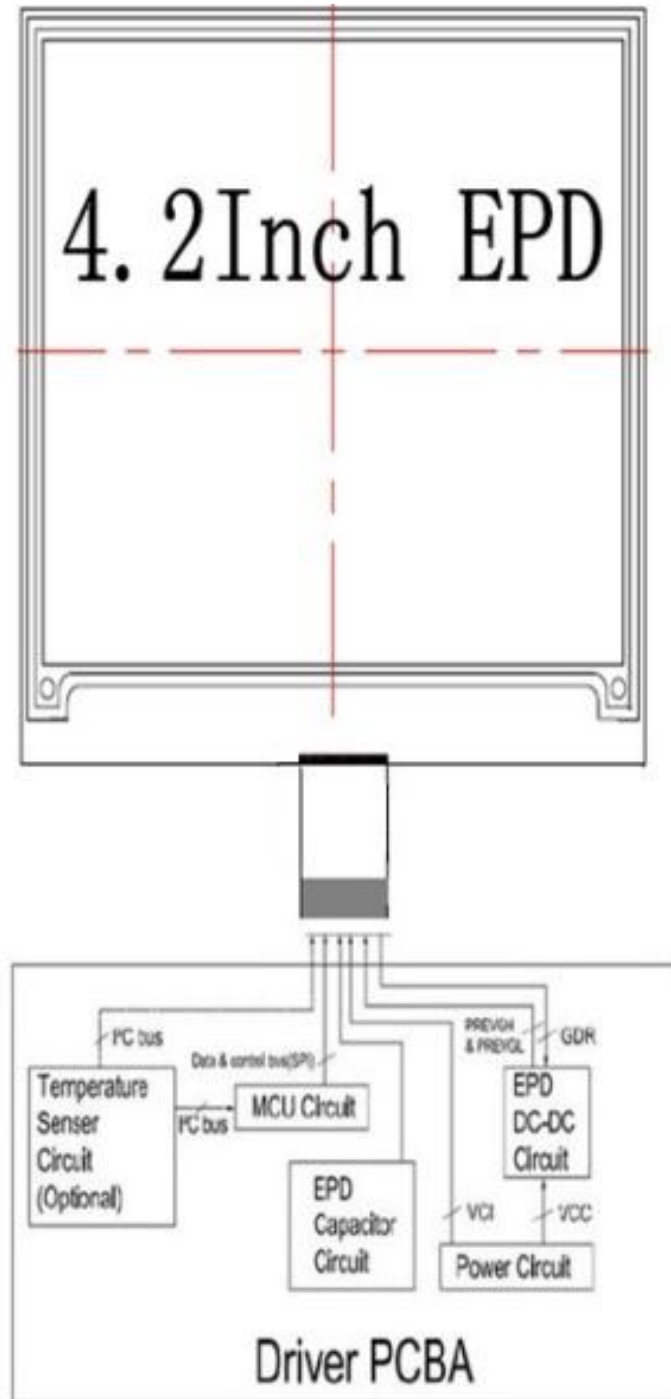
## 10. Reliability Test

NO	Test items	Test condition
1	Low-Temperature Storage	T = -25°C, 240 h Test in white pattern
2	High-Temperature Storage	T = +70°C, RH=40% ,240h Test in white pattern
3	High-Temperature Operation	T = +50°C, RH = 30% ,240h
4	Low-Temperature Operation	0°C, 240h
5	High-Temperature, High-Humidity Operation	T=+40°C, RH=90%,240h
6	High Temperature, High Humidity Storage	T=+60°C, RH=80%,240h Test in white pattern
7	Temperature Cycle	1 cycle:[-25°C 30min]→[+70 °C 30 min] : 100 cycles Test in white pattern
8	UV exposure Resistance	765W/m <sup>2</sup> for 168hrs,40 °C Test in white pattern
9	ESD Gun	Air+/-15KV;Contact+/-8KV (Test finished product shell,not display only) Air+/-8KV;Contact+/-6KV (Naked EPD display,no including IC and FPC area) Air+/-4KV;Contact+/-2KV (Naked EPD display,including IC and FPC area)

**Note: Put in normal temperature for 1hour after test finished, display performance is ok.**

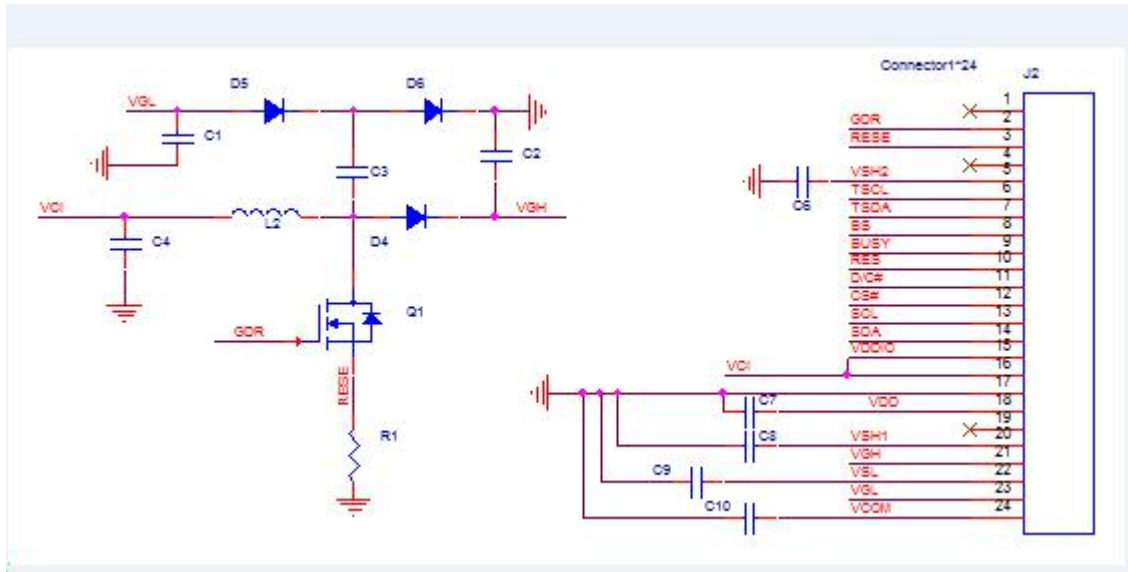


### 11. Block Diagram





## 12. Typical Application Circuit with SPI Interface



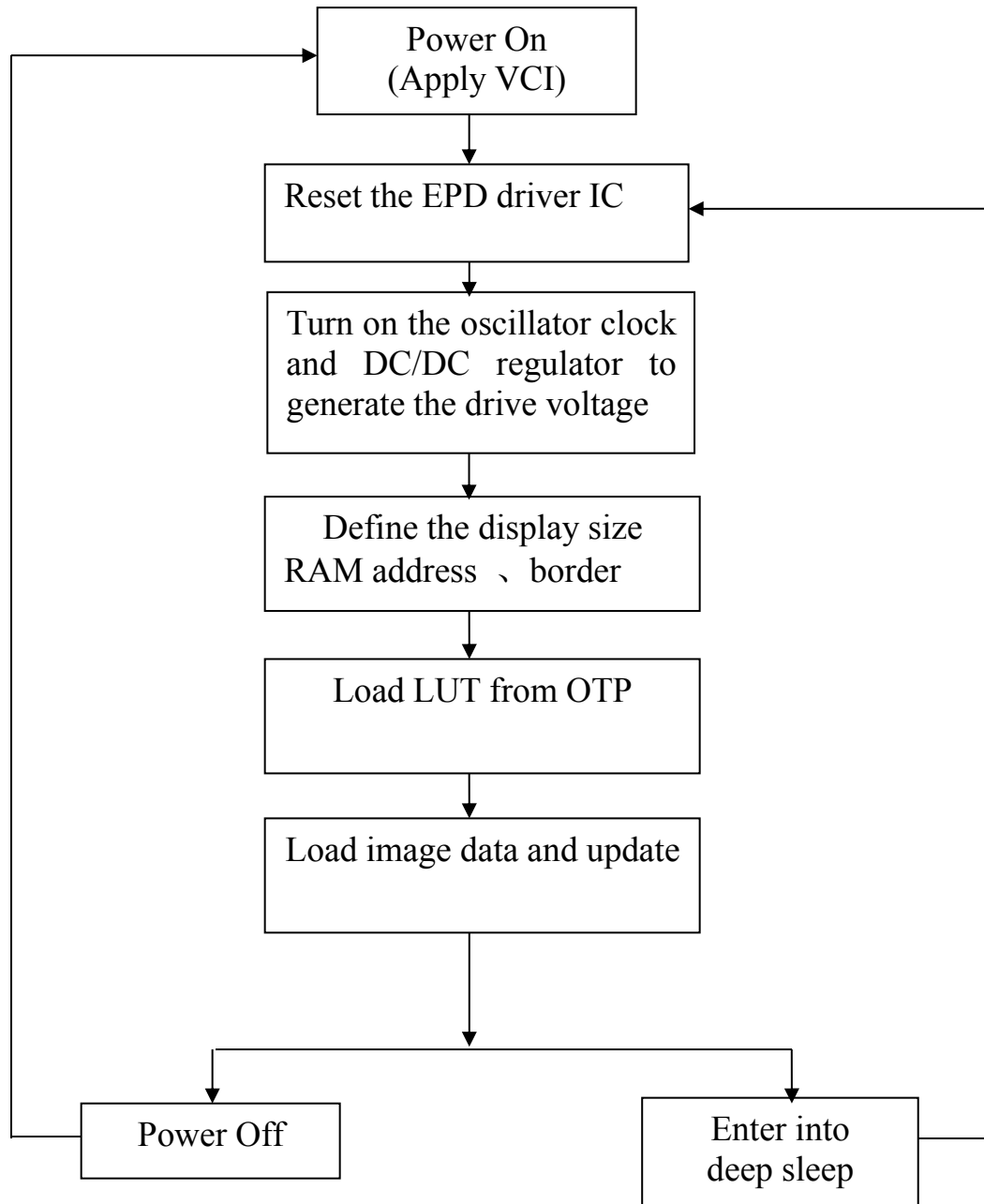
Part Name	Value	Reference Part	Requirements for spare part
C4 C7	1uF	0603;X5R/X7R;Voltage Rating:6v	
C1 C2 C3 C6 C8 C9	1uF	0805; X5R/X7R;Voltage Rating:25v	
C10	0.47uF	0805; X7R;Voltage Rating:25v	
R1	3.0Ohm	0805; 1%	
D4 D5 D6	Diode	MBR0530	
Q1	NMOS	Si1304BDL	
L2	10uH	CDRH2D18/LDNP-100NC	





## 13 Typical Operating Sequence

### 13.1 LUT from OTP Operation Flow



**13.2 LUT from OTP Operation Reference Program Code**

ACTION	VALUE/DATA	COMMENT
POWER ON		
delay	10ms	
PIN CONFIG		
RESE#	low	Hardware reset
delay	200us	
RESE#	high	
delay	200us	
Read busy pin		Wait for busy low
Command 0x12		Software reset
Read busy pin		Wait for busy low
Command 0x74	Data 0x54	Set Analog Block Control
Command 0x7E	Data 0x3B	Set Digital Block Control
Command 0x2B	Data 0x04 0x63	Write Register for VCOM Control
Command 0x0C	Data 0x8B 0x9C 0x96 0x0F	Set Booster Soft start
Command 0x01	Data 0x2B 0x01 0x00	Set display size and driver output control
Command 0x11	Data 0x01	Ram data entry mode
Command 0x44	Data 0x00 0x31	Set Ram X address
Command 0x45	Data 0x2B 0x01 0x000x00	Set Ram Y address
Command 0x3C	Data 0x01	Set border
LOAD LUT		
Command 0x18	Data 0x80	Set built-in temperature sensor
Command 0x22	Data 0xB1	Load LUT
Command 0x20		
Read busy pin		Wait for busy low
LOAD IMAGE AND UPDATE		
Command 0x4E	Data 0x00	Set Ram X address counter
Command 0x4F	Data 0x2B 0x01	Set Ram Y address counter
Command 0x24	15000bytes	Load BW image (400/8*300)
Command 0x22	Data 0xC7	Image update
Command 0x20		
Read busy pin		Wait for busy low
Command 0x10	Data 0X01	Enter deep sleep mode
POWER OFF		



## 14. Part Number Definition

QYEG0420BNS19AF0  
1 2 3 4 5 6 7

- 1: QYE: QY EPD
- 2: G:Dot matrix type
- 3: The E-paper size:4.2inch:0420
- 4: The color of E-paper:  
B : Black/White R: Black/White/Red Y: Black/White/Yellow
- 5: OT range: N: Normal L/S: Low temperature H/W: High temperature
- 6: Driver type: internal temperature sensor
- 7: FPC type

## 15. Inspection condition

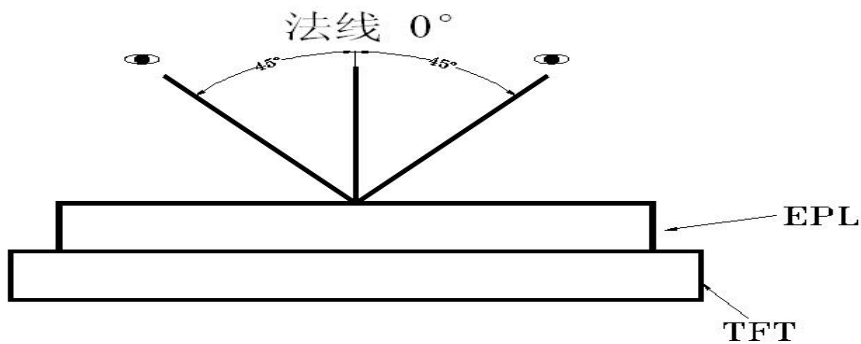
### 15.1 Environment

Temperature:  $23\pm 3^{\circ}\text{C}$   
Humidity:  $55\pm 10\%\text{RH}$

### 15.2 Illuminance

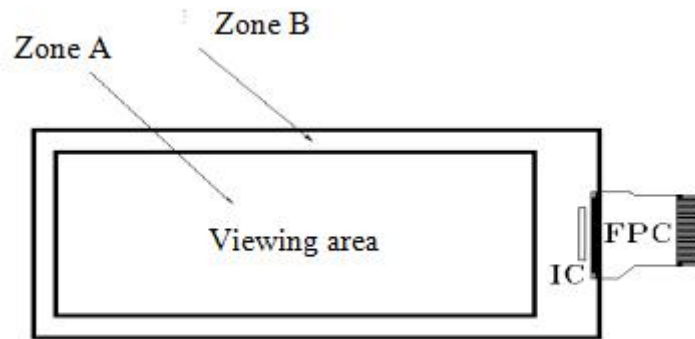
Brightness:1200~1500LUX;distance: 30CM;Angle:Relate  $45^{\circ}$ surround.

### 15.3 Inspect method






### 15.4 Display area

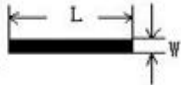


### 15.5 Inspection standard

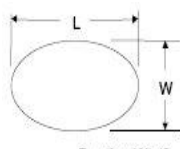
#### 15.5.1 Electric inspection standard

NO.	Item	Standard	Defect level	Method	Scope
1	Display	Clear display Display complete Display uniform	MA	Visual inspection	Zone A
2	Black/White spots	 $D \leq 0.3\text{mm}$ , Allowed $0.3\text{mm} < D \leq 0.5\text{mm}$ , $N \leq 5$ , $0.5\text{mm} < D$ Not Allow	MI		

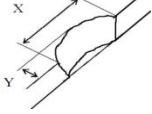
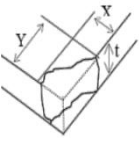
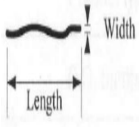



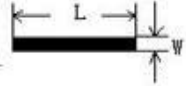


3	Black/White spots (No switch)	 $L \leq 1.0\text{mm}, W \leq 0.15\text{mm}$ negligible $1.0\text{mm} < L \leq 4.0\text{mm}$ $0.15\text{mm} < W \leq 0.5\text{mm}$ $N \leq 4$ allowable $L > 4.0\text{mm}, W > 0.5\text{mm}$ is not allowed			
4	Ghost image	Allowed in switching process	MI	Visual inspection	
5	Flash dot / Multilateral	Flash points are allowed when switching screens Multilateral colors outside the frame are allowed for fixed screen time	MI	Visual/ Inspection card	Zone A Zone B
6	Segmented display	Selection segments are all displayed, and other segments are not displayed after the selection segment.	MA	Visual inspection	Zone A
7	Short circuit/ Circuit break/ Abnormal Display	Not Allow			

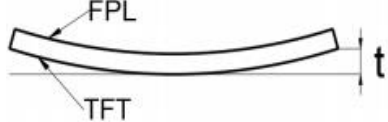
**15.5.2 Appearance inspection standard**

NO.	Item	Standard	Defect level	Method	Scope
1	B/W spots /Bubble/ Foreign bodies/ Dents	 $D = (L + W) / 2$ $D \leq 0.3\text{mm}$ , Allowed $0.3\text{mm} < D \leq 0.5\text{mm}$ , $N \leq 5$ $D > 0.5\text{mm}$ , Not Allow	MI	Visual inspection	Zone A
2	Glass crack	Not Allow	MA	Visual / Microscope	Zone A Zone B
3	\Dirty	Allowed if can be removed	MI		Zone A Zone B



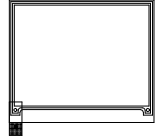
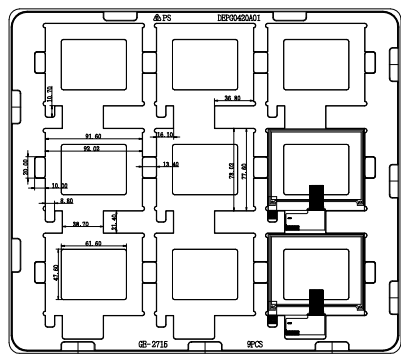
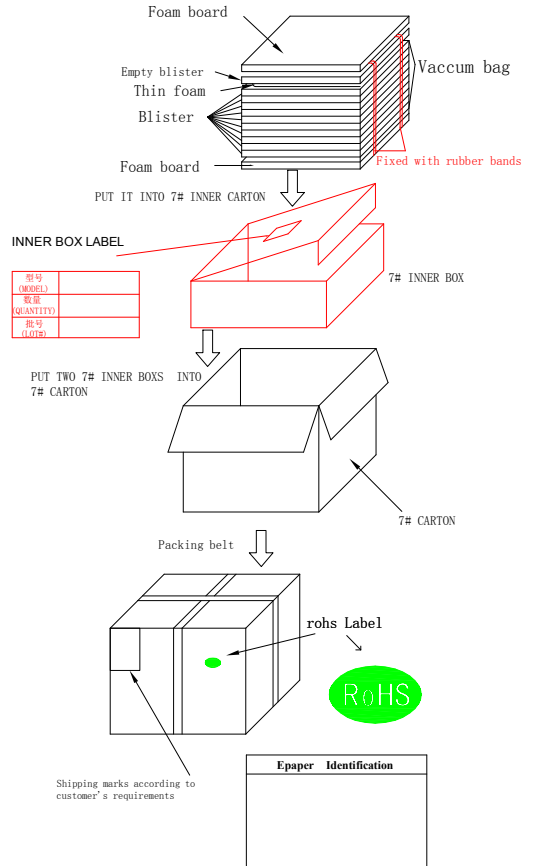
4	Chips/Scratch/ Edge crown	 <p><math>X \leq 3\text{mm}, Y \leq 0.5\text{mm}</math></p>  <p><math>2\text{mm} \leq X \text{ or } 2\text{mm} \leq Y</math> Allow</p>  <p><math>W \leq 0.1\text{mm}, L \leq 5\text{mm}, n \leq 2</math> Edge crown: <math>X \leq 0.3\text{mm}, Y \leq 3\text{mm}</math></p>	MI	Visual / Microscope	Zone A Zone B
5	TFT Cracks	 <p>Not Allow</p>	MA	Visual / Microscope	Zone A Zone B
6	Dirty/ foreign body	Allowed if can be removed/ allow	MI	Visual / Microscope	Zone A / Zone B
7	FPC broken/ FPC oxidation / scratch	  <p>Not Allow</p>	MA	Visual / Microscope	Zone B
8	B/W Line	 <p><math>L \leq 1.0\text{mm}, W \leq 0.15\text{mm}</math> negligible <math>1.0\text{mm} &lt; L \leq 4.0\text{mm}</math> <math>0.15\text{mm} &lt; W \leq 0.5\text{mm}</math> <math>N \leq 4</math> allowable <math>L &gt; 4.0\text{mm}, W &gt; 0.5\text{mm}</math> is not allowed</p>	MI	Visual / Ruler	Zone B
9	TFT edge bulge /TFT chromatic aberration	TFT edge bulge: $X \leq 3\text{mm}, Y \leq 0.3\text{mm}$ Allowed TFT chromatic aberration :Allowed	MI	Visual / Microscope	Zone A Zone B



10	Electrostatic point	$D \leq 0.25\text{mm}$ , allow $0.25\text{mm} < D \leq 0.4\text{mm}$ , $n \leq 4$ allow $D > 0.4\text{mm}$ is not allowed ( $n \leq 8$ items are allowed within 5 mm in diameter)	MI	Visual / Microscope	Zone A
11	PCB damaged/ Poor welding/ Curl	PCB (Circuit area) damaged Not Allow PCB Poor welding Not Allow PCB Curl $\leq 1\%$	MI	Visual / Ruler	Zone B
12	Edge glue height/ Edge glue bubble	Edge Adhesives $H \leq \text{PS surface}$ (Including protect film) Edge adhesives seep in $\leq 1/2$ Margin width Length excluding Edge adhesives bubble: bubble Width $\leq 1/2$ Margin width; Length $\leq 0.5\text{mm}$ . $n \leq 5$	MI		
13	Protect film	Surface scratch but not effect protect function, Allow	MI	Visual Inspection	
14	Silicon glue	Thickness $\leq \text{PS surface}$ (With protect film): Full cover the IC; Shape: The width on the FPC $\leq 0.5\text{mm}$ (Front) The width on the FPC $\leq 1.0\text{mm}$ (Back) smooth surface, No obvious raised.	MI	Visual Inspection	
15	Warp degree (TFT substrate)	 <p><math>t \leq 1.5\text{mm}</math></p>	MI	Ruler	
16	Color difference in COM area (Silver point area)	Allowed		Visual Inspection	



# 16.Packaging

<h2 style="margin: 0;">EPD PACKING INSTRUCTION</h2> <p style="margin: 0;">QY-QS. D-010</p>						<table border="1" style="width: 100%; border-collapse: collapse;"> <tr><td style="font-size: small;">DATE</td><td> </td></tr> <tr><td style="font-size: small;">DESIGN</td><td> </td></tr> <tr><td style="font-size: small;">CHECKED</td><td> </td></tr> <tr><td style="font-size: small;">APPROVED</td><td> </td></tr> </table>	DATE		DESIGN		CHECKED		APPROVED																																		
DATE																																															
DESIGN																																															
CHECKED																																															
APPROVED																																															
<table border="1" style="width: 100%; border-collapse: collapse;"> <tr> <th style="font-size: x-small;">P/N</th> <th style="font-size: x-small;">Customer Code</th> <th style="font-size: x-small;">Ref. P/N</th> </tr> <tr> <td style="text-align: center;">QYEG0420</td> <td> </td> <td> </td> </tr> </table>	P/N	Customer Code	Ref. P/N	QYEG0420			<table border="1" style="width: 100%; border-collapse: collapse;"> <tr> <th style="font-size: x-small;">Type</th> <th style="font-size: x-small;">PKG Method</th> <th style="font-size: x-small;">Printing</th> <th style="font-size: x-small;">Surface Marks</th> <th style="font-size: x-small;">Pull Tape</th> <th style="font-size: x-small;">Bar. Code</th> </tr> <tr> <td style="text-align: center;">GLASS</td> <td style="text-align: center;">Blister</td> <td style="text-align: center;">BACK</td> <td style="text-align: center;">None</td> <td style="text-align: center;">YES</td> <td style="text-align: center;">None</td> </tr> </table>	Type	PKG Method	Printing	Surface Marks	Pull Tape	Bar. Code	GLASS	Blister	BACK	None	YES	None	<p>Marks instruction:</p> <p style="text-align: center;">print on the back of the product</p> <p>Contents: model+Lot#</p>		<p>Pull tape:</p> 																									
P/N	Customer Code	Ref. P/N																																													
QYEG0420																																															
Type	PKG Method	Printing	Surface Marks	Pull Tape	Bar. Code																																										
GLASS	Blister	BACK	None	YES	None																																										
<p><b>Packing Materials List</b></p> <table border="1" style="width: 100%; border-collapse: collapse;"> <thead> <tr> <th style="font-size: x-small;">List</th> <th style="font-size: x-small;">Model</th> <th style="font-size: x-small;">Materials</th> <th style="font-size: x-small;">Q'ty</th> <th style="font-size: x-small;">Unit</th> </tr> </thead> <tbody> <tr><td>Carton</td><td>7#</td><td>corrugate</td><td>1</td><td>Piece</td></tr> <tr><td>BOX</td><td>7#(INNER)</td><td>corrugate</td><td>2</td><td>Piece</td></tr> <tr><td>Blister</td><td>QYEG0420A01</td><td>PET</td><td>22</td><td>Piece</td></tr> <tr><td>Thin foam</td><td>295.6*269.6*T1.8-2.0</td><td>EPE</td><td>20</td><td>Piece</td></tr> <tr><td>Vaccum bag</td><td>450.0*590.0*0.075</td><td> </td><td>2</td><td>Piece</td></tr> <tr><td>Foam board</td><td>QY2251-10</td><td>EPE</td><td>5</td><td>Piece</td></tr> <tr><td>PULL TAPE</td><td>16* 5.0</td><td> </td><td>180</td><td>Piece</td></tr> </tbody> </table>			List	Model	Materials	Q'ty	Unit	Carton	7#	corrugate	1	Piece	BOX	7#(INNER)	corrugate	2	Piece	Blister	QYEG0420A01	PET	22	Piece	Thin foam	295.6*269.6*T1.8-2.0	EPE	20	Piece	Vaccum bag	450.0*590.0*0.075		2	Piece	Foam board	QY2251-10	EPE	5	Piece	PULL TAPE	16* 5.0		180	Piece	<p>9PCS/LAYER, 20 LAYER/CTN, TOTAL 180PCS/CTN.</p>			<p>Barcode Instruction:</p>	
List	Model	Materials	Q'ty	Unit																																											
Carton	7#	corrugate	1	Piece																																											
BOX	7#(INNER)	corrugate	2	Piece																																											
Blister	QYEG0420A01	PET	22	Piece																																											
Thin foam	295.6*269.6*T1.8-2.0	EPE	20	Piece																																											
Vaccum bag	450.0*590.0*0.075		2	Piece																																											
Foam board	QY2251-10	EPE	5	Piece																																											
PULL TAPE	16* 5.0		180	Piece																																											
<p>Detail:</p>																																															
<p>Blister box:</p> <p>NOTE:</p> <p style="text-align: center;">TOTAL 10 LAYERS PER INNER BOX WITH ONE MORE EMPTY BLISTER ON THE TOP OF THE PRODUCTS.</p>  <p style="text-align: center; margin-top: 10px;"><b>QUANTITY: 9PCS</b></p>			 <p style="font-size: x-small; margin-top: 10px;">Shipping marks according to customer's requirements</p>																																												