



CB2L Module Datasheet

Version: 20220818

Contents

1	Product overview	2
1.1	Features	2
1.2	Applications	2
2	Module interfaces	4
2.1	Dimensions and package	4
2.2	Pin definition	4
2.3	Definitions of test points	5
3	Electrical parameters	7
3.1	Absolute electrical parameters	7
3.2	Normal working conditions	7
3.3	RF power consumption	8
3.4	Operating current	8
4	RF parameters	11
4.1	Basic RF features	11
4.2	Wi-Fi transmission performance	11
4.3	Wi-Fi receiving performance	12
4.4	Bluetooth transmission performance	12
4.5	Bluetooth receiving performance	13
5	Antenna information	14
5.1	Antenna type	14
5.2	Antenna interference reduction	14
6	Packaging information and production instructions	17
6.1	Mechanical dimensions	17
6.2	Side view	19
6.3	Schematic diagram of packaging	20
6.4	Diagram of PCB footprint-pin header	20
6.5	Production instructions	22
6.6	Recommended oven temperature curve	24
6.7	Storage conditions	27

7	MOQ and packaging information	28
8	Appendix-Statement	29



CB2L is a low-power-consumption embedded Wi-Fi module that Tuya has developed. It consists of a highly integrated RF chip BK7231N and a few peripherals. CB2L not only supports the Wi-Fi AP and STA modes, but also supports the Bluetooth LE.

1 Product overview

CB2L is built in with a 32-bit MCU whose running speed can be up to 120 MHz, a 2-MB flash memory, and a 256-KB RAM, so as to support the Tuya cloud connection. The MCU instructions specially extended for signal processing can effectively implement audio encoding and decoding. There are 5 channels of 32-bit PWM output, making the chip very suitable for high-quality LED control.

1.1 Features

- Built in with the low-power 32-bit CPU, which can also function as an application processor
- Clock rate: 120 MHz
- Operating voltage: 3.0 to 3.6V
- Peripherals: 5 PWMs
- Wi-Fi connectivity
 - 802.11 b/g/n
 - Channels 1 to 14@2.4 GHz

 - Support WEP, WPA/WPA2, WPA/WPA2 PSK (AES), WPA3 security modes
 - Up to +16 dBm output power in 802.11b mode
 - Support STA/AP/STA+AP working mode
 - Support SmartConfig and AP network configuration manners for Android and iOS devices
 - Onboard PCB antenna with a gain of 1.9 dBi
 - Operating temperature: -40°C to 105°C
- Bluetooth connectivity
 - Support the Bluetooth LE V5.2
 - Support the transmit power of 6 dBm in the Bluetooth mode
 - Complete Bluetooth coexistence interface

 - Onboard PCB antenna with a gain of 1.9 dBi

1.2 Applications

- Intelligent building

- Smart household and home appliances
- Smart socket and light
- Industrial wireless control
- Baby monitor
- Network camera
- Intelligent bus

2 Module interfaces

2.1 Dimensions and package

- CB2L has a row of pins with the spacing of 2 ± 0.1 mm.
- The dimensions of CB2L are 17.3 ± 0.35 mm (L) \times 15 ± 0.35 mm (W) \times 2.8 ± 0.15 mm (H).
- Diagram of dimensions of CB2L:

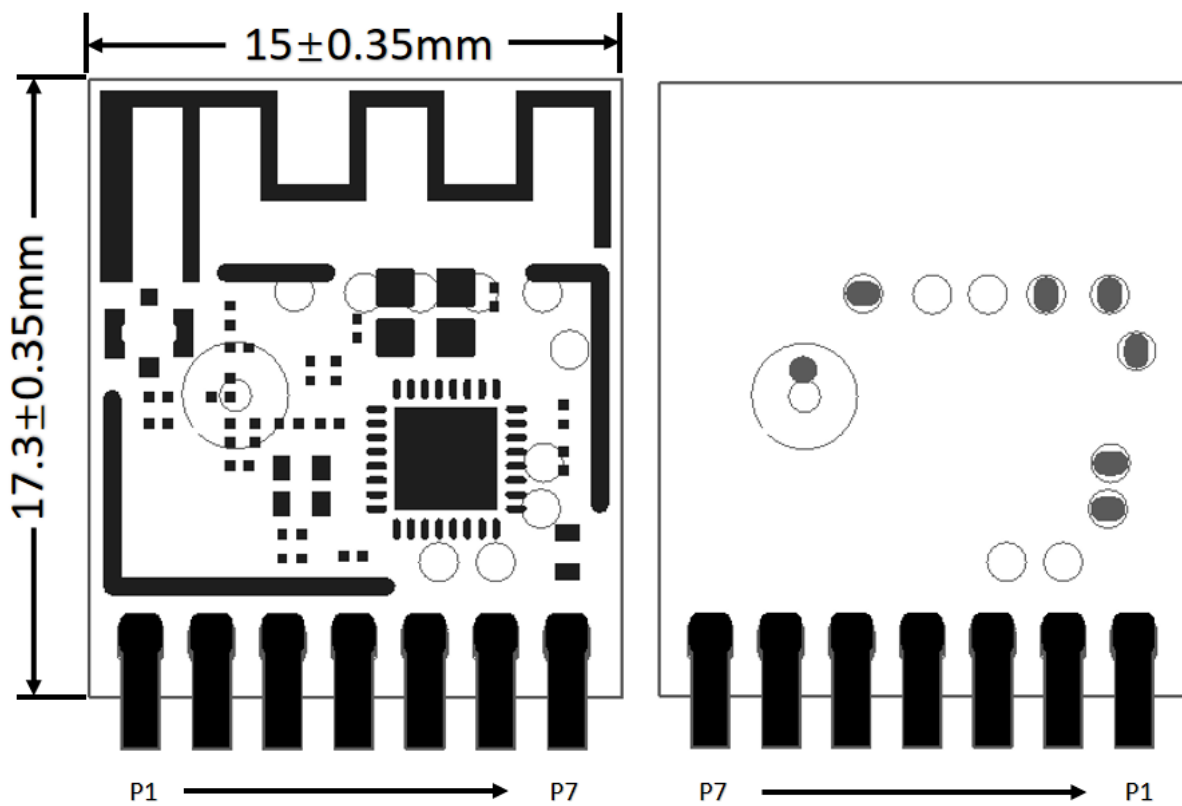

Figure 1: CB2L.png

2.2 Pin definition

Pin number	Symbol	I/O type	Function
1	P8	I/O	Support hardware PWM
2	P7	I/O	Support hardware PWM
3	P6	I/O	Support hardware PWM
4	P26	I/O	Support hardware PWM
5	P24	I/O	Support hardware PWM
6	GND	P	Power supply reference ground
7	3V3	P	Power supply 3V3

2.3 Definitions of test points

Pin number	Symbol	I/O type	Function
-	CSN	I/O	It' s a mode selection pin. If it is connected to ground before powered on, enter the firmware test mode. If it is not connected or connected to VCC before powered on, enter the firmware application mode. Correspond to P21 of the IC
-	RST	I	Hardware reset pin; by default, high level; active low
-	TX1	I/O	UART1_TX, user serial interface
-	RX1	I/O	UART1_RX, user serial interface
-	TX2	I/O	LOG TX
-	GND	P	Power supply reference ground
-	RF	I/O	RF test point

Note: P indicates a power supply pin and I/O indicates an input/output pin.

3 Electrical parameters

3.1 Absolute electrical parameters

Parameter	Description	Minimum value	Maximum value	Unit
T _s	Storage temperature	-55	125	°C
V _{BAT}	Supply voltage	-0.3	3.9	V
ESD voltage (human body model)	TAMB-25°C	-4	4	KV
ESD voltage (machine model)	TAMB-25°C	-200	200	V

3.2 Normal working conditions

Parameter	Description	Minimum value	Typical value	Maximum value	Unit
T _a	Operating temperature	-40	-	105	°C
V _{BAT}	Supply voltage	3	3.3	3.6	V
V _{OL}	I/O low level output	VSS	-	VSS+0.3	V
V _{OH}	I/O high level output	V _{BAT} -0.3	-	V _{BAT}	V

Parameter	Description	Minimum value	Typical value	Maximum value	Unit
I _{max}	I/O drive current	-	6	20	mA

3.3 RF power consumption

Working status	Mode	Rate	Transmit power/receive	Average value	Peak value (Typical value))	Unit
Transmit	11b	11Mbps	+16dBm	270	300	mA
Transmit	11g	54Mbps	+15dBm	260	280	mA
Transmit	11n	MCS7	+14dBm	253	273	mA
Receive	11b	11Mbps	Constantly receive	73	82	mA
Receive	11g	54Mbps	Constantly receive	75	82	mA
Receive	11n	MCS7	Constantly receive	75	82	mA

3.4 Operating current

Working mode	Working status, Ta = 25°C	Average value	Maximum value (Typical value)	Unit
Quick network connection state (Bluetooth)	The module is in the fast network connection state and the Wi-Fi indicator flashes fast	70	270	mA
Quick network connection state (AP)	The module is in the hotspot network connection state and the Wi-Fi indicator flashes slowly	80	305	mA
Quick network connection state (EZ)	The module is in the fast network connection state and the Wi-Fi indicator flashes fast	87	380	mA
Network connected state	The module is connected to the network and the Wi-Fi indicator is always on	39	355	mA

Working mode	Working status, Ta = 25°C	Average value	Maximum value (Typical value)	Unit
Weakly connected	The module and the hotspot are weakly connected and the Wi-Fi indicator is always on	205	350	mA
Network disconnected state	The module is disconnected and the Wi-Fi indicator is always off	70	270	mA

4 RF parameters

4.1 Basic RF features

Parameter	Description
Working frequency	2.412 to 2.484 GHz
Wi-Fi standard	IEEE 802.11 b/g/n (channels 1 to 14)
Data transmission rate	11b: 1, 2, 5.5, 11 (Mbps); 11g: 6, 9, 12, 18, 24, 36, 48, 54 (Mbps); 11n: HT20 MCS 0 to 7; 11n: HT40 MCS 0 to 7
Antenna type	PCB antenna with a gain of 1.9 dBi

4.2 Wi-Fi transmission performance

Parameter	Minimum value	Typical value	Maximum value	Unit
Average RF output power, 802.11b CCK Mode 11M	-	16	-	dBm
Average RF output power, 802.11g OFDM Mode 54M	-	15	-	dBm
Average RF output power, 802.11n OFDM Mode MCS7	-	14	-	dBm

Parameter	Minimum value	Typical value	Maximum value	Unit
Frequency error	-20	-	20	ppm

4.3 Wi-Fi receiving performance

Parameter	Minimum value	Typical value	Maximum value	Unit
PER<8%, RX sensitivity, 802.11b DSSS Mode 11M	-	-88	-	dBm
PER<10%, RX sensitivity, 802.11g OFDM Mode 54M	-	-74	-	dBm
PER<10%, RX sensitivity, 802.11n OFDM Mode MCS7	-	-72	-	dBm
PER<10%, RX sensitivity, Bluetooth 1M	-	-93	-	dBm

4.4 Bluetooth transmission performance

Parameter	Minimum value	Typical value	Maximum value	Unit
Working frequency	2402	-	2480	MHz
Air rate	-	1	-	Mbps
Transmit power	-20	6	20	dBm
Frequency error	-150	-	150	KHz

4.5 Bluetooth receiving performance

Parameter	Minimum value	Typical value	Maximum value	Unit
RX sensitivity	-	-93	-	dBm
Maximum RF signal input	-10	-	-	dBm
Inter-modulation	-	-	-23	dBm
Co-channel suppression ratio	-	10	-	dB

5 Antenna information

5.1 Antenna type

CB2L uses the PCB antenna.

5.2 Antenna interference reduction

To ensure optimal Wi-Fi performance when the Wi-Fi module uses an onboard PCB antenna, it is recommended that the antenna be at least 15 mm away from other metal parts.

To prevent adverse impact on the antenna radiation performance, avoid copper or traces along the antenna area on the PCB.

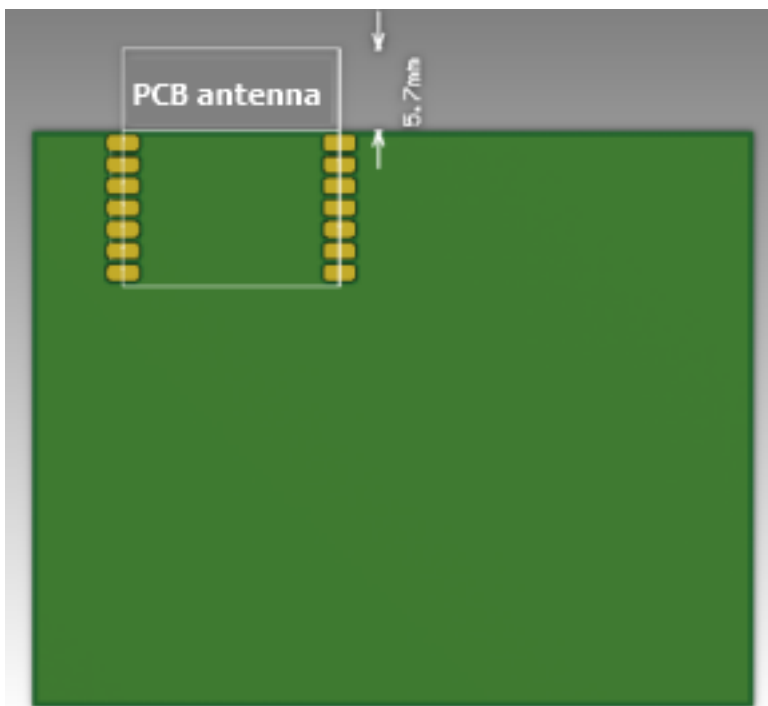

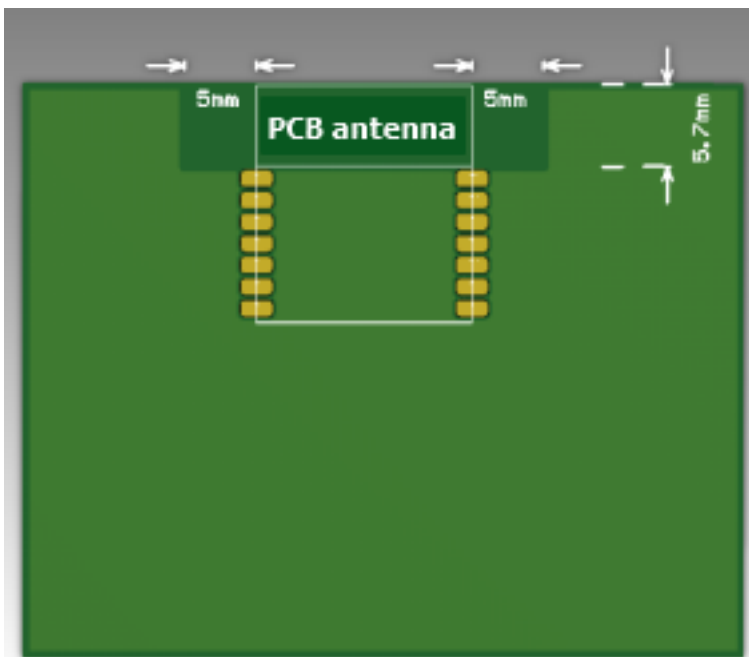
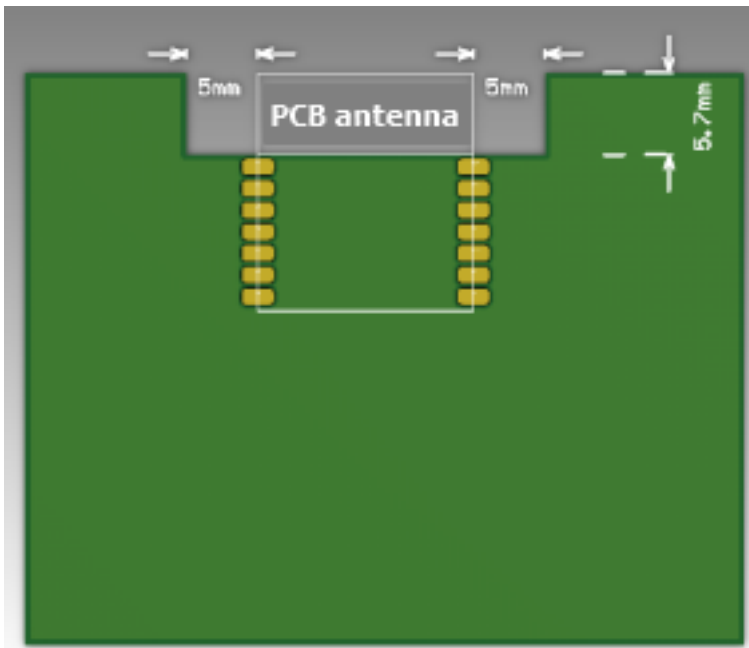

**Do not place any metal in the red area above the antenna.
The recommended diameter of the circular arc is greater than 3 cm.**

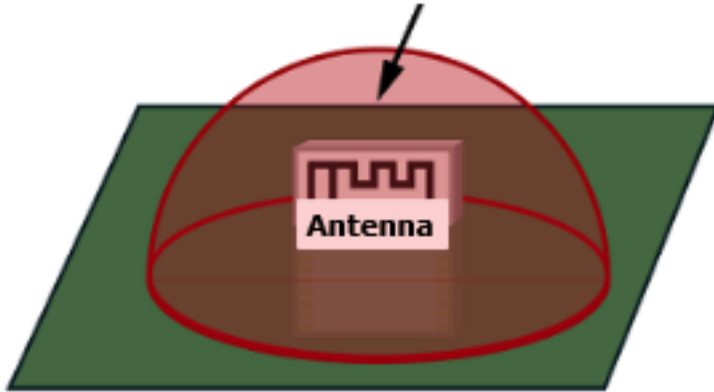

6 Packaging information and production instructions

6.1 Mechanical dimensions

The dimensions of the PCB are 17.3 ± 0.35 mm (L) \times 15 ± 0.35 mm (W) \times 0.8 ± 0.1 mm (H).

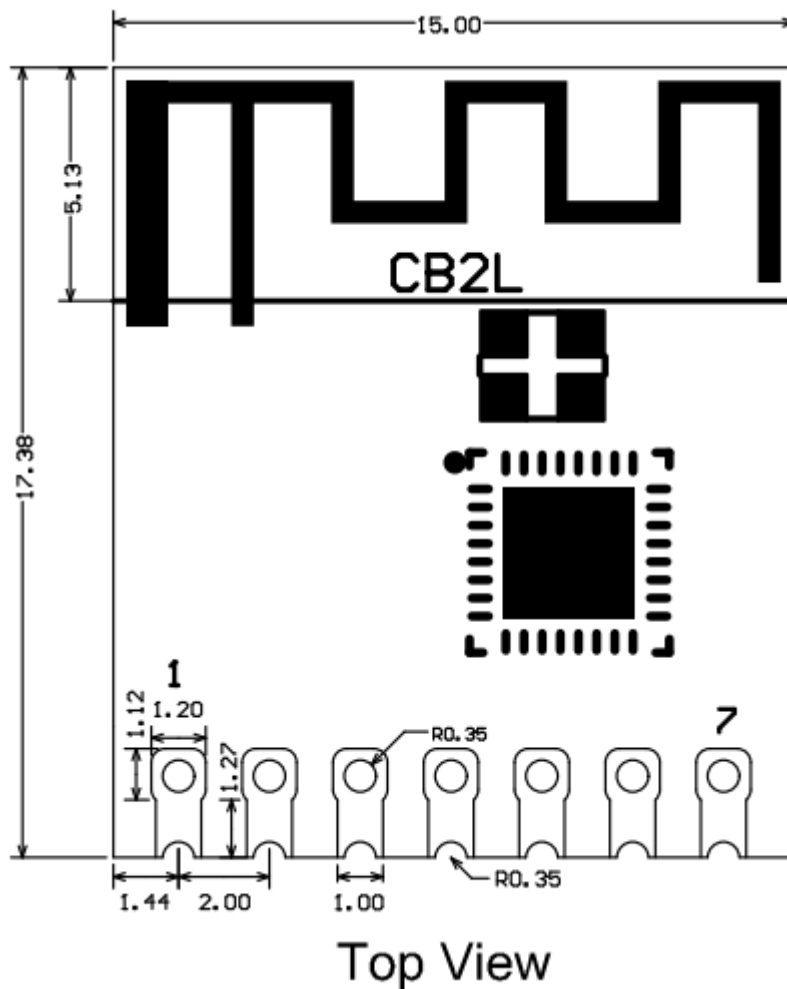

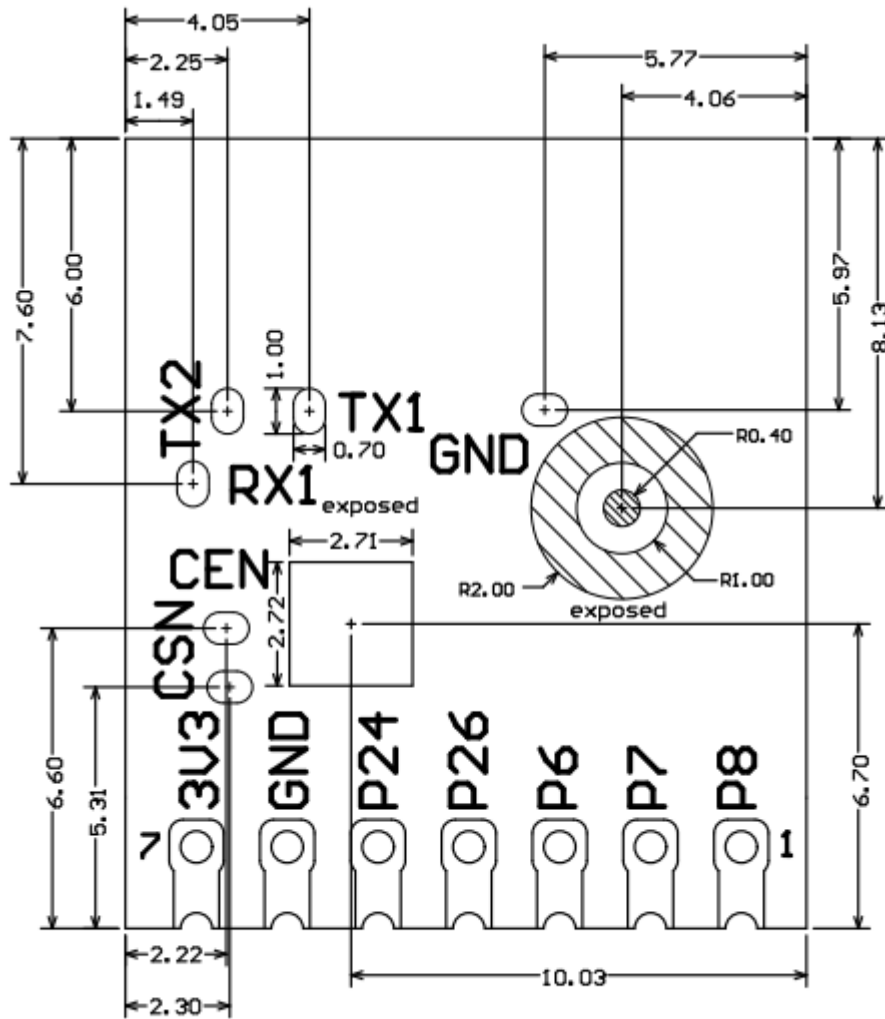

Bottom View

6.2 Side view

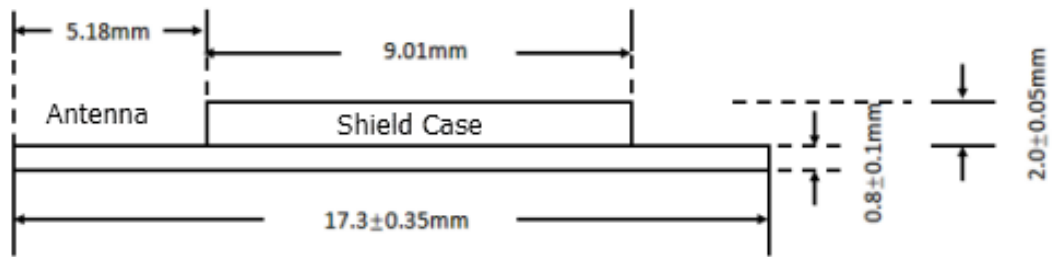

6.3 Schematic diagram of packaging

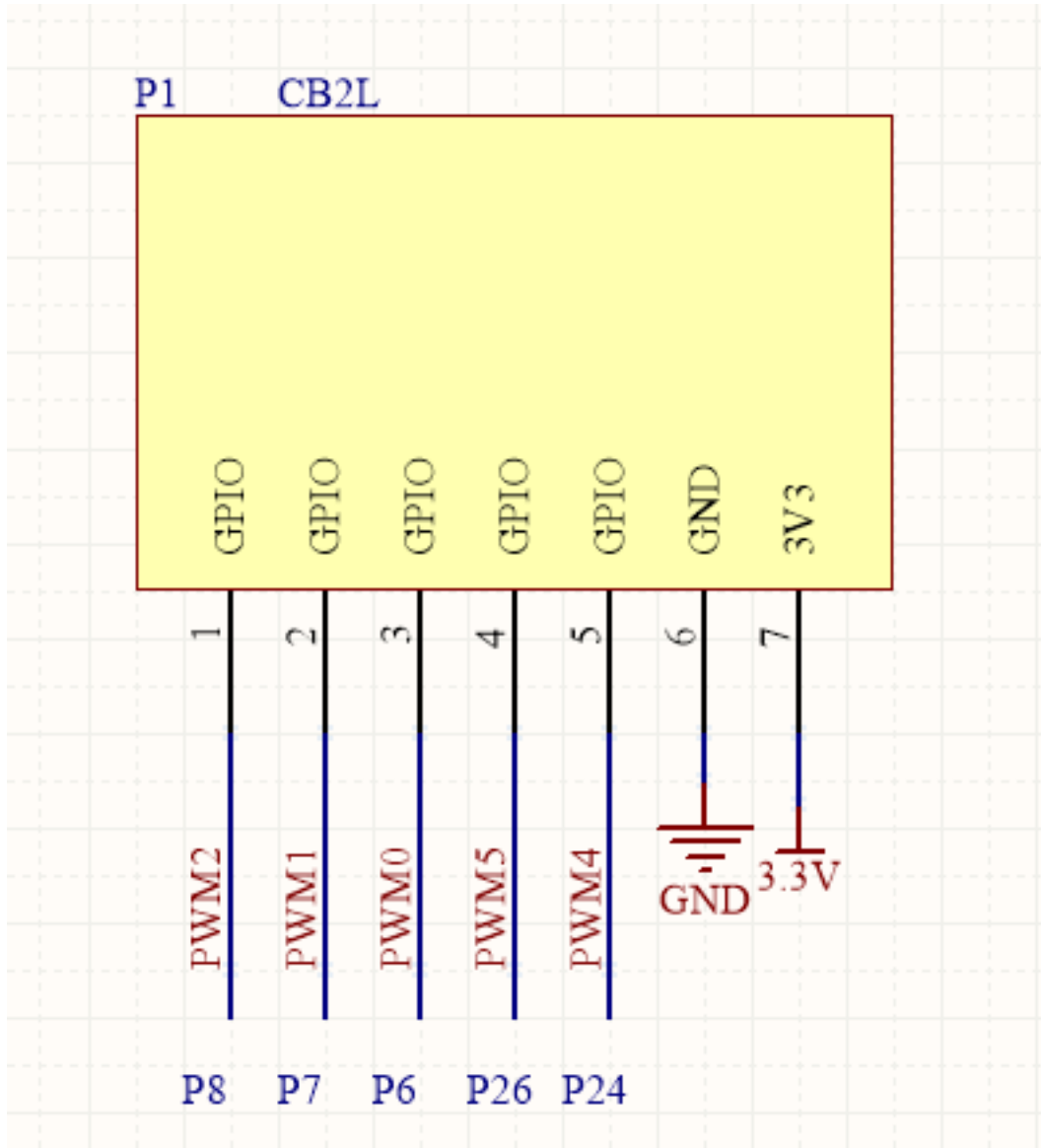

6.4 Diagram of PCB footprint-pin header

CB2L can be packaged with the SMT or pin header. The dimensions for the plug-in are as follows:

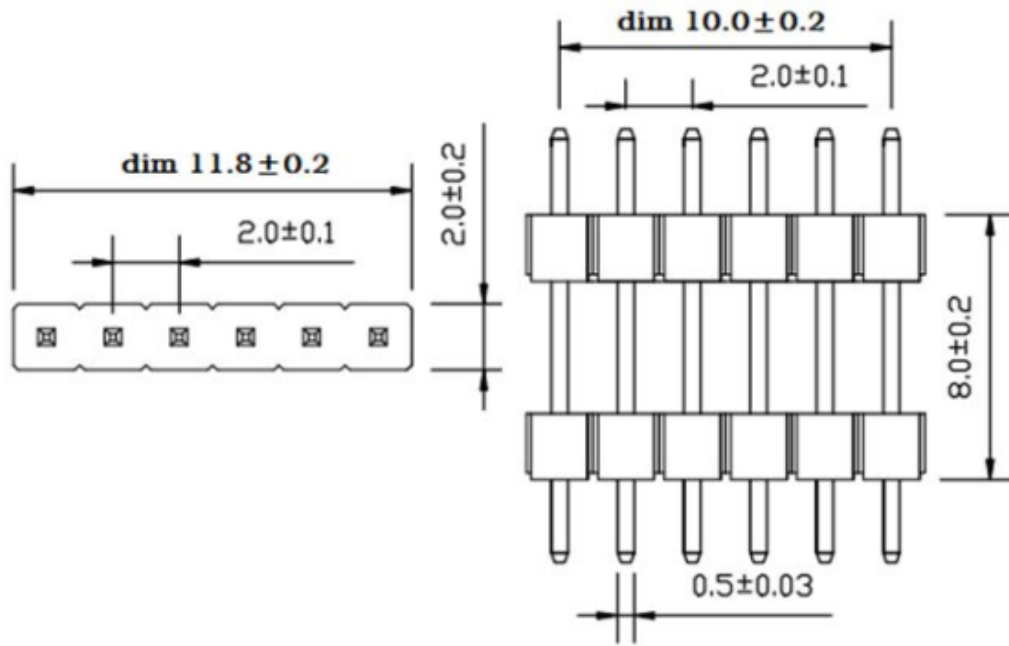

6.4.1 PCB footprint-SMT

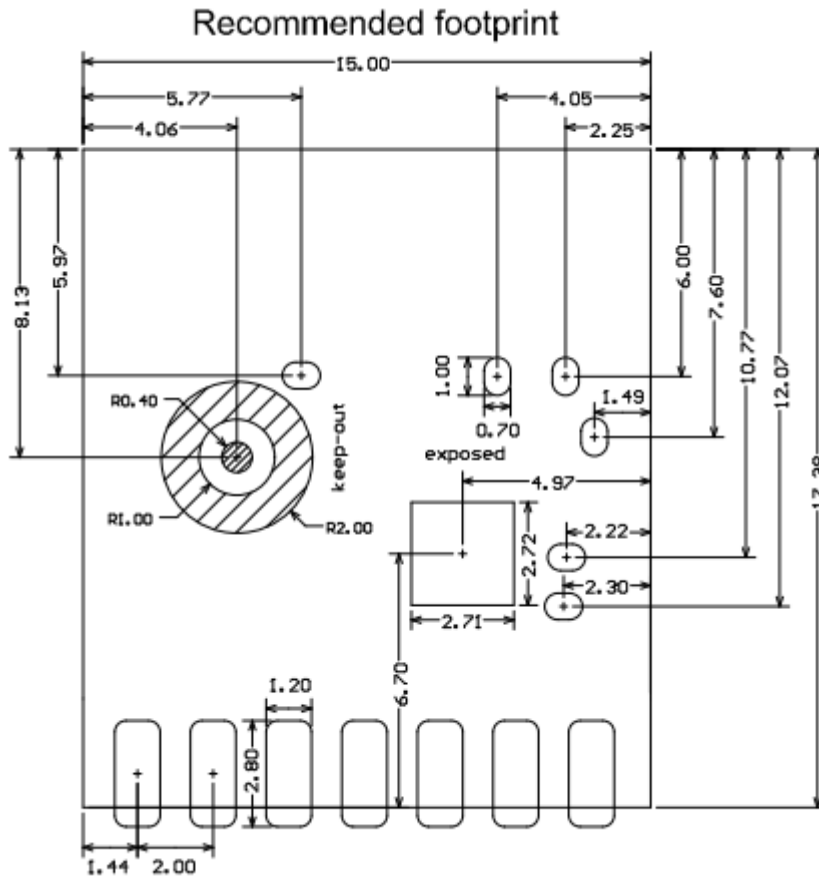

6.5 Production instructions

1. For the modules that can be packaged with the SMT or in an in-line way, you can select either of them according to the PCB design solutions of customers. If a PCB is designed to be SMT-packaged, package the module with the SMT. If a PCB is designed to be in-line-packaged, package the module in an in-line way. After being unpacked, the module must be soldered within 24 hours. Otherwise, it needs to be put into the drying cupboard where the relative humidity is not greater than 10%; or it needs to be packaged again under vacuum and the exposure time needs to be recorded (the total exposure time cannot exceed 168 hours).

- (SMT process) SMT devices:
 - Mounter
 - SPI
 - Reflow soldering machine
 - Thermal profiler
 - Automated optical inspection (AOI) equipment
- (Wave soldering process) Wave soldering devices:
 - Wave soldering equipment
 - Wave soldering fixture
 - Constant-temperature soldering iron
 - Tin bar, tin wire, and flux
 - Thermal profiler
- Baking devices:
 - Cabinet oven
 - Anti-electrostatic and heat-resistant trays
 - Anti-electrostatic and heat-resistant gloves

2. Storage conditions for a delivered module:

- The moisture-proof bag must be placed in an environment where the temperature is below 40°C and the relative humidity is lower than 90%.
- The shelf life of a dry-packaged product is 12 months from the date when the product is packaged and sealed.
- There is a humidity indicator card (HIC) in the packaging bag.

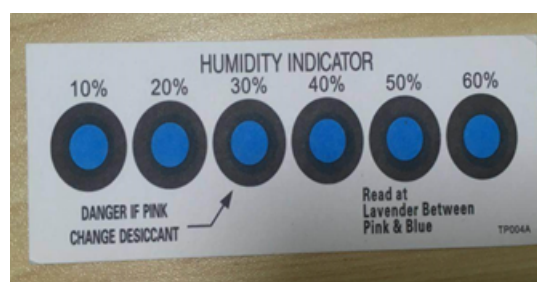

Figure 2: HIC-SMT and in-line module.png

3. The module needs to be baked in the following cases:

- The packaging bag is damaged before unpacking.
- There is no humidity indicator card (HIC) in the packaging bag.

- After unpacking, circles of 10% and above on the HIC become pink.
- The total exposure time has lasted for over 168 hours since unpacking.
- More than 12 months have passed since the sealing of the bag.

4. Baking settings:

- Temperature: 40°C and $\leq 5\%$ RH for reel package and 125°C and $\leq 5\%$ RH for tray package (please use the heat-resistant tray rather than a plastic container)
- Time: 168 hours for reel package and 12 hours for tray package
- Alarm temperature: 50°C for reel package and 135°C for tray package
- Production-ready temperature after natural cooling: $< 36^\circ\text{C}$
- Re-baking situation: If a module remains unused for over 168 hours after being baked, it needs to be baked again.
- If a batch of modules is not baked within 168 hours, do not use the reflow soldering or wave soldering to solder them. Because these modules are Level-3 moisture-sensitive devices, they are very likely to get damp when exposed beyond the allowable time. In this case, if they are soldered at high temperatures, it may result in device failure or poor soldering.

5. In the whole production process, take electrostatic discharge (ESD) protective measures.

6. To guarantee the passing rate, it is recommended that you use the SPI and AOI to monitor the quality of solder paste printing and mounting.

6.6 Recommended oven temperature curve

Select a proper soldering manner according to the process. For the SMT process, please refer to the recommended oven temperature curve of reflow soldering. For the wave soldering process, please refer to the recommended oven temperature curve of wave soldering. There are some differences between the set temperatures and the actual temperatures. All the temperatures shown in this module datasheet are obtained through actual measurements.

Manner 1: SMT process (Recommended oven temperature curve of reflow soldering)

Set oven temperatures according to the following curve.

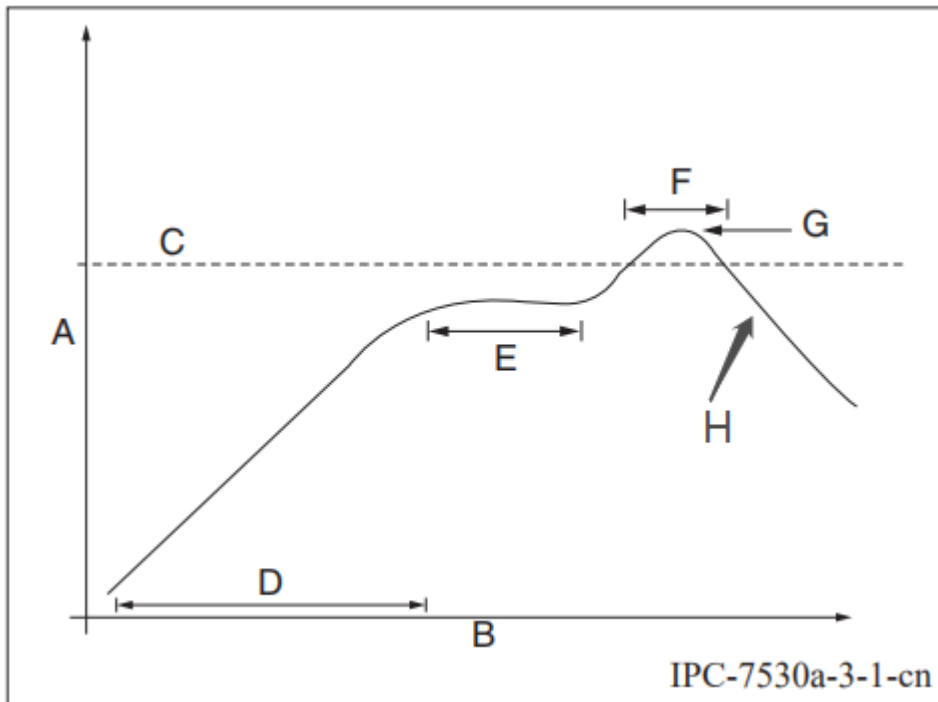

- A: Temperature axis
- B: Time axis
- C: Liquidus temperature: 217 to 220°C
- D: Ramp-up slope: 1 to 3°C/s
- E: Duration of constant temperature: 60 to 120s; the range of constant temperature: 150 to 200°C
- F: Duration above the liquidus: 50 to 70s
- G: Peak temperature: 235 to 245°C
- H: Ramp-down slope: 1 to 4°C/s

Note: The above curve is just an example of the solder paste SAC305. For more details about other solder pastes, please refer to Recommended oven temperature curve in the solder paste specifications.

Manner 2: Wave soldering process (Oven temperature curve of wave soldering)

Set oven temperatures according to the following temperature curve of wave soldering. The peak temperature is 260°C±5°C.

DIP Type Product Pass Wavesolder Graph

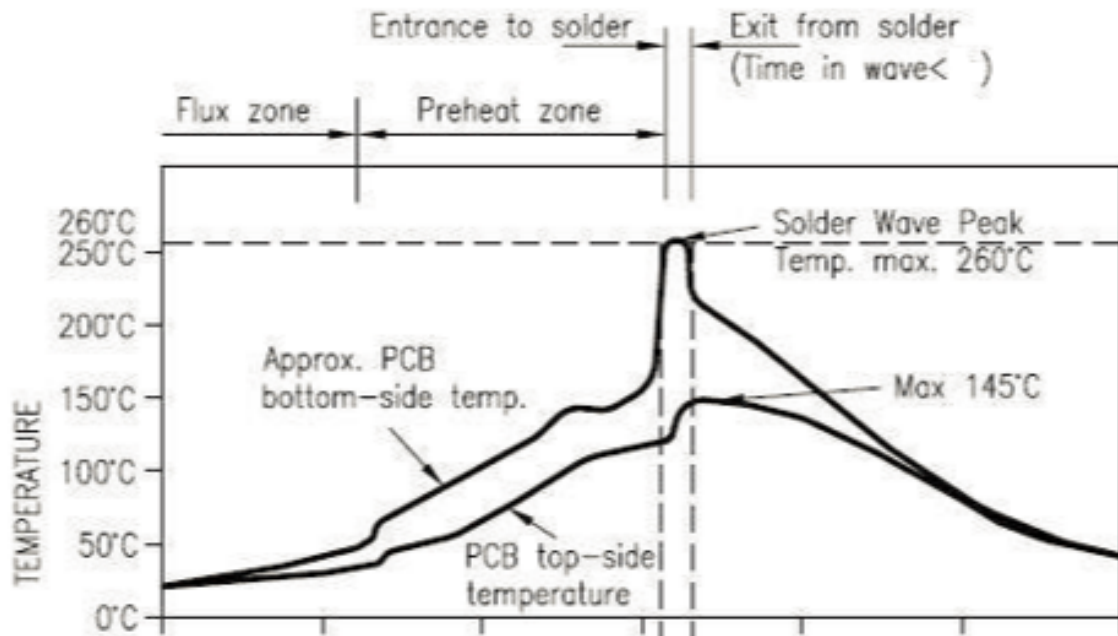

Suggestions on oven temperature curve of wave soldering

Suggestions on manual soldering temperature

Preheat temperature	80 to 130 °C	Soldering temperature	360±20°C
Preheat time	75 to 100s	Soldering time	< 3s/point
Peak contact time	3 to 5s	NA	NA
Temperature of tin cylinder	260±5°C	NA	NA
Ramp-up slope	≤2°C/s	NA	NA
Ramp-down slope	≤6°C/s	NA	NA

6.7 Storage conditions

	<p>Caution This bag contains MOISTURE-SENSITIVE DEVICES</p>	<p>LEVEL 3</p> <p><small>If blank, see adjacent bar code label</small></p>
<p>1. Calculated shelf life in sealed bag: 12 months at <math><40^{\circ}\text{C}</math> and <math><90\%</math> relative humidity (RH)</p>		
<p>2. Peak package body temperature: <u> 260 </u> $^{\circ}\text{C}$ <small>If blank, see adjacent bar code label</small></p>		
<p>3. After bag is opened, devices that will be subjected to reflow solder or other high temperature process must be</p>		
<p>a) Mounted within: <u> 168 </u> hours of factory conditions <small>If blank, see adjacent bar code label</small> $\leq 30^{\circ}\text{C}/60\% \text{ RH}$, or</p>		
<p>b) Stored per J-STD-033</p>		
<p>4. Devices require bake, before mounting, if:</p>		
<p>a) Humidity Indicator Card reads >10% for level 2a - 5a devices or >60% for level 2 devices when read at $23 \pm 5^{\circ}\text{C}$</p>		
<p>b) 3a or 3b are not met</p>		
<p>5. If baking is required, refer to IPC/JEDEC J-STD-033 for bake procedure</p>		
<p>See Production Date</p>		
<p>Bag Seal Date: _____ <small>If blank, see adjacent bar code label</small></p>		
<p>Note: Level and body temperature defined by IPC/JEDEC J-STD-020</p>		

7 MOQ and packaging information

Product model	MOQ (pcs)	Shipping packaging method	Modules per reel	Reels per carton
CB2L	4000	Tape reel	1000	4

8 Appendix-Statement

FCC Caution: Any changes or modifications not expressly approved by the party responsible for compliance could void the user's authority to operate this device.

This device complies with Part 15 of the FCC Rules. Operation is subject to the following two conditions: (1) This device may not cause harmful interference, and (2) this device must accept any interference received, including interference that may cause undesired operation.

Note: This device has been tested and found to comply with the limits for a Class B digital device, according to part 15 of the FCC Rules. These limits are designed to provide reasonable protection against harmful interference in a residential installation. This device generates, uses, and can radiate radio frequency energy and, if not installed and used following the instructions, may cause harmful interference to radio communications. However, there is no guarantee that interference will not occur in a particular installation.

If this device does cause harmful interference to radio or television reception, which can be determined by turning the device off and on, the user is encouraged to try to correct the interference by one or more of the following measures:

- Reorient or relocate the receiving antenna.
- Increase the separation between the device and receiver.
- Connect the device to an outlet on a circuit different from that to which the receiver is connected.
- Consult the dealer or an experienced radio/TV technician for help.

Radiation Exposure Statement

This device complies with FCC radiation exposure limits set forth for an uncontrolled rolled environment. This device should be installed and operated with a minimum distance of 20cm between the radiator and your body.

Important Note

This radio module must not be installed to co-locate and operate simultaneously with other radios in the host system except following FCC multi-transmitter product procedures. Additional testing and device authorization may be required to operate simultaneously with other radios.

The availability of some specific channels and/or operational frequency bands are country dependent and are firmware programmed at the factory to match the intended destination. The firmware setting is not accessible by the end-user.

The host product manufacturer is responsible for compliance with any other FCC rules that apply to the host not covered by the modular transmitter grant of certification. The final host product still requires Part 15 Subpart B compliance testing with the modular transmitter installed.

The end-user manual shall include all required regulatory information/warnings as shown in this manual, including “This product must be installed and operated with a minimum distance of 20 cm between the radiator and user body” .

This device has got an FCC ID: 2ANDL-CB2L. The end product must be labeled in a visible area with the following: “Contains Transmitter Module FCC ID: 2ANDL-CB2L” .

This device is intended only for OEM integrators under the following conditions:

The antenna must be installed such that 20cm is maintained between the antenna and users, and the transmitter module may not be co-located with any other transmitter or antenna.

As long as the 2 conditions above are met, further transmitter tests will not be required. However, the OEM integrator is still responsible for testing their end-product for any additional compliance requirements required with this module installed.

Declaration of Conformity European Notice



Hereby, Hangzhou Tuya Information Technology Co., Ltd declares that this module product is in compliance with essential requirements and other relevant provisions of Directive 2014/53/EU,2011/65/EU. A copy of the Declaration of conformity can be found at <https://www.tuya.com>.



This product must not be disposed of as normal household waste, in accordance with the EU directive for waste electrical and electronic equipment (WEEE-2012/19/EU). Instead, it should be disposed of by returning it to the point of sale, or to a municipal recycling collection point.

The device could be used with a separation distance of 20cm to the human body.